

O-LINE™

MICRO LINE ARRAY

NOW WITH SCALABLE RESOLUTION
TO TAME ANY SPACE



Unite Your Audience
The Martin Audio Experience



O-LINE™

O-Line is an award-winning, aesthetically pleasing, modular micro line array designed for a wide variety of architectural applications – from houses of worship to transport terminals. It combines innovative acoustic design with powerful optimisation software to achieve optimum coverage with unprecedented accuracy over a pre-defined area.

In many applications an O-Line array can be driven using only one amplifier channel, with simple EQ and limiting the only processing required.

It can now also be taken into a new dimension of coverage consistency and control when used with an iK81 amplifier, or combination of VIA2004 amplifier and DX4.0 controller, to independently control and power each individual enclosure or groups of enclosures. This unlocks the full potential of O-Line — further refining coverage consistency and increasing the ability to ‘dial-out’ the influence of the room by accessing DISPLAY’s ‘hard avoid’ capability and electronically adjustable coverage.

Unlike many DSP ‘steered’ columns, an O-Line array does not produce unwanted vertical sidelobes in the audio band. This is critical in reverberant environments as sidelobes firing above and below the array simply adds to the reverberant energy, impacting on intelligibility. O-Line’s ability to reproduce very high frequencies without sidelobes makes it the ideal solution for both full-range speech and music reproduction in reverberant spaces.

An O-Line array is finished in a neutral light grey that blends into the background of most architectural spaces, with modular design in multiples of four cabinets. Sonically, it is very clean and musical, and capable of surprisingly high output levels for its very small size with 16 cabinets capable of an astonishing 134dB [peak] and a throw distance of up to 40 metres.



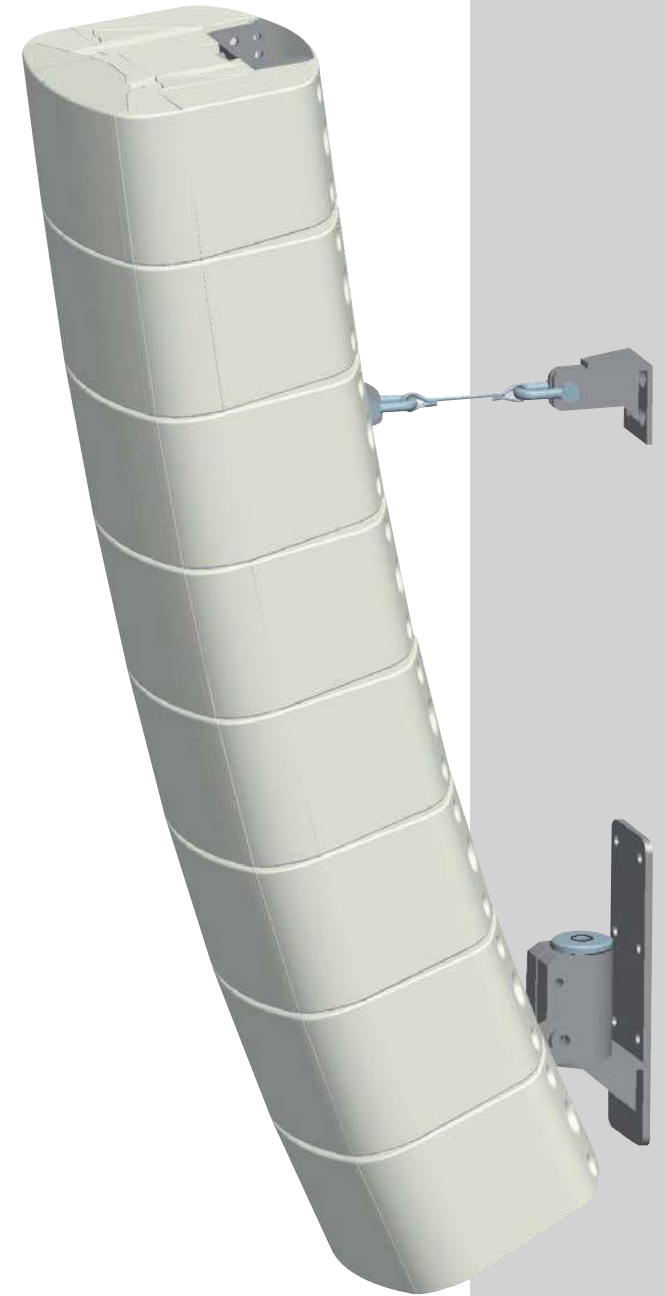
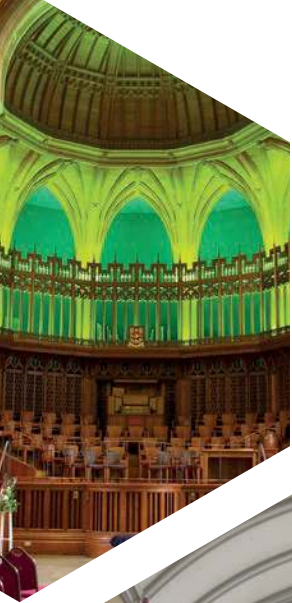

FEATURES

- Modular micro line array for maximum deployment flexibility
- Software optimised array configuration for focused sound energy
- Additional DSP optimised functionality for increased coverage consistency and control.
- Sidelobe-free vertical dispersion from the high frequency section
- Ideal for high-quality music reproduction as well as speech
- Architecturally sympathetic design for discreet deployment

APPLICATIONS

- Houses of worship
- Museums
- Conference centres, auditoria and lecture theatres
- Transport terminals, shopping malls and sports venues
- Bars and restaurants

DISPLAY™ OPTIMISATION, AMPLIFICATION AND CONTROL

In its standard set up with uniform amplification, it is the articulation of individual array modules that delivers the consistent sound coverage over a defined area. The array configuration for a specific area is determined by industry leading DISPLAY optimisation software which makes intelligent judgements about how well the array performs against objective target functions. This enables focused sound energy to be delivered precisely where needed and kept away from reflective surfaces and ceilings — reducing the detrimental influence of the room and increasing clarity and intelligibility in challenging acoustic environments.

This can now be taken further with DSP optimisation delivered via DISPLAY 2.3 and use of an iK81 amplifier, or combination of VIA2004 amplifier and DX4.0 controller, to independently control and power each individual enclosure, or groups of enclosures. This unlocks the full potential of O-Line — further refining coverage consistency and increasing the ability to ‘dial-out’ the influence of the room by accessing DISPLAY’s ‘hard avoid’ capability and electronically adjustable coverage.

This can also offer additional practical benefits to any installation. More often than not, many installations can suffer from height restrictions, and the combination of both mechanical and DSP optimisation can address this challenge. Similarly, some installations require a flatter array for aesthetic reasons and additional DSP optimisation can compensate for the resultant reduction in mechanical optimisation available. There is also the scenario that following an installation something changes in the venue. In this situation, rather than having to de-rig and re-rig, electronic optimisation alone can provide a useful level of coverage change. Similarly, it may be that the venue is multi-purpose with changing sizes of audience. By using DISPLAY with VU-NET control in this case, it’s possible to have different pre-sets to cater for these coverage changes.

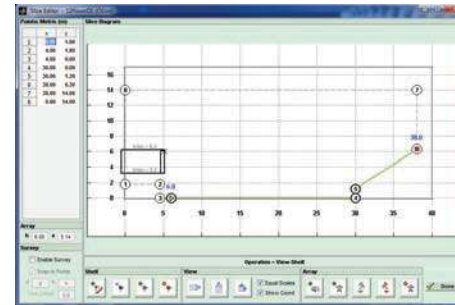

Step 1: Venue entry

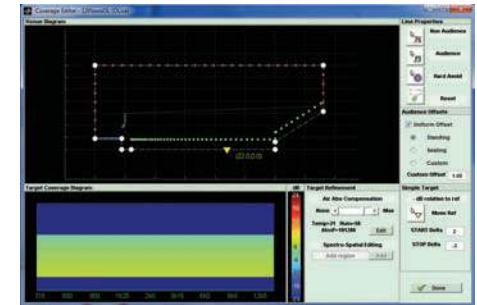

Step 2: Set coverage parameters

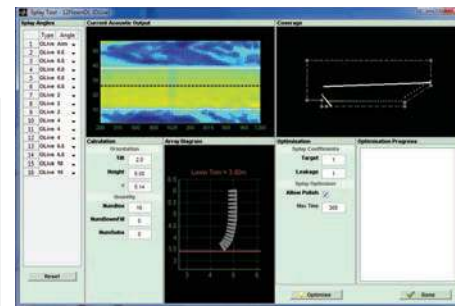

Step 3: Calculate splay angles



Step 4: Optimisation and upload

Operating Mode	Benefits
Individual enclosure drive with iK81 or combination of VIA2004 and DX4.0	<ul style="list-style-type: none"> Ultimate front-to-rear coverage consistency. ‘Hard- avoid’ capability to further reduce room influence. Electronically adjustable coverage if changes are required. Compensation for lack of ideal array height. Compensation for lack of mechanical articulation (flat array).
Uniform drive with single amplifier channel.	<ul style="list-style-type: none"> Highly consistent front-to-rear coverage. Reduced room influence.



iKON iK81

The iK81 is an advanced eight-channel amplifier which combines very high power density with superb audio performance. It features onboard IIR and FIR filtering to control the amplitude, phase and EQ of each O-Line module individually, with the filter parameters calculated and uploaded by DISPLAY. The iK81 also employs comprehensive protection functions to maintain safe operating conditions of both the amplifier and the O-Line.

Alternative a system can be optimised with a combination of VIA2004 and DX4.0. The VIA 2004 is an advanced 4-channel power amplifier which delivers superb audio performance in a lightweight, cost-effective package. DX4.0 is an advanced loudspeaker controller and system matrix with four input and eight output channels. Class-leading sonic performance is achieved by state-of-the-art audio converters and DSP algorithms, with a 96kHz sampling frequency delivering a nominally flat response beyond 40kHz. It features FIR filtering to support O-Line optimisation.

The level of coverage, consistency and control is further refined by the level of resolution of the array in terms of the number of enclosures to amp channels. The higher the resolution, so too the improvement in coverage and consistency of frequency response and SPLs throughout the venue within a tight window specified by the user.

In the ultimate one enclosure to one amplifier channel mode [One Box Resolution] it is possible to



VIA 2004



DX4.0

simultaneously optimise the direct field where sound is required, keep the sound away from reflective surfaces and minimise reverberant sound power to an extent not previously possible from a commercially available system of such high sound quality, small size and aesthetic appeal.

Ethernet is used for system remote control and monitoring via Martin Audio's VU-NET software application, while a user-friendly front panel interface allows full local control of all features. Dante digital audio network inputs are also provided for digital audio distribution and control.

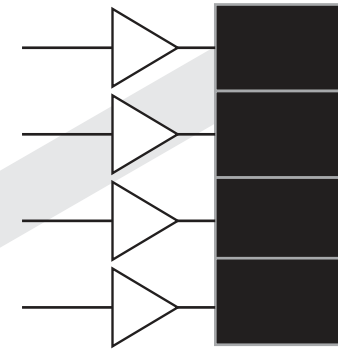

One Box Resolution

1 Top Box to 1 Amp Channel

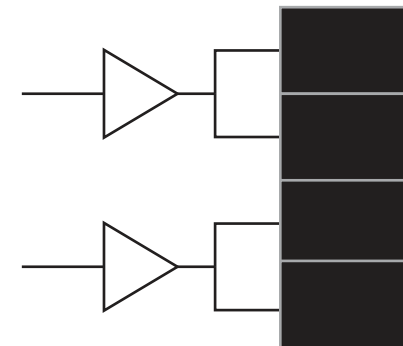

Two Box Resolution

2 Top Boxes to 1 Amp Channel

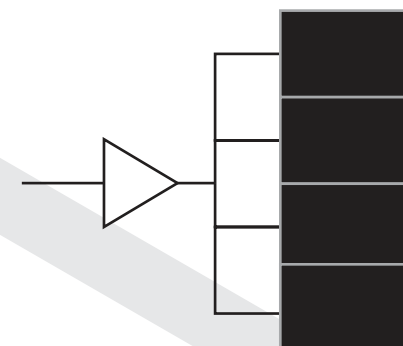

Four Box Resolution

4 Top Boxes to 1 Amp Channel





O-LINE™
MICRO LINE ARRAY
NOW WITH SCALABLE RESOLUTION
TO TAME ANY SPACE

“O-Line has proved ideal for awkward, multi-purpose spaces with difficult acoustics, where a discreet solution is required

Colin Hasted, Pure AV

SCALABLE RESOLUTION – THE IMPACT ON COVERAGE CONSISTENCY AND CONTROL

O-Line with iK81 amplifiers – or combination of VIA2004 amplifiers and DX4.0 controllers - provides scalable resolution from 8 box to 1 box resolution. As resolution increases so too does the level of coverage consistency and control that can be achieved.

O-Line -16 box hang – 8 box resolution

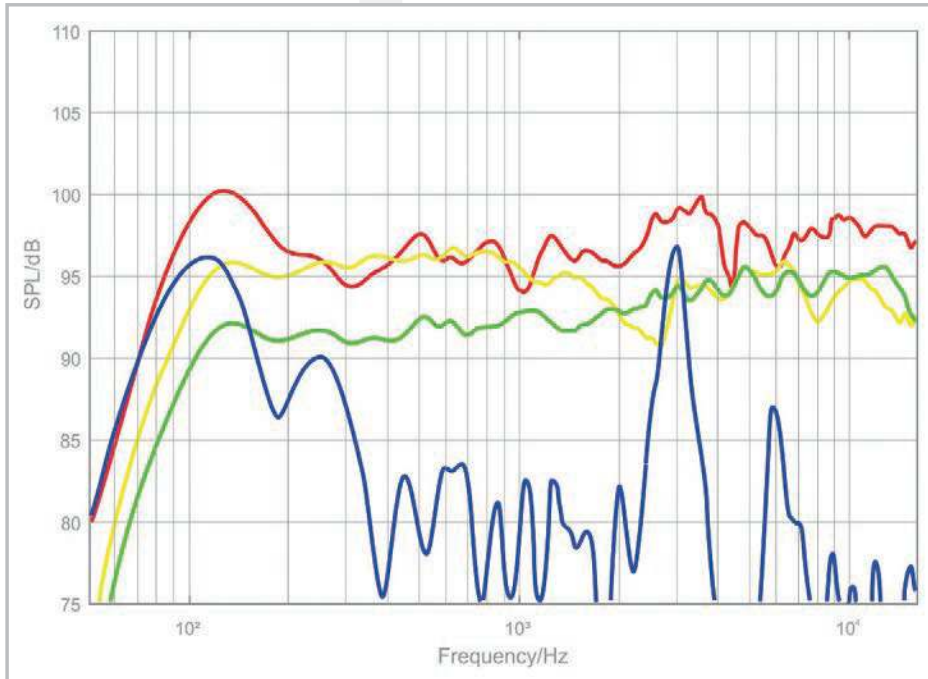

O-Line -16 box hang – 1 box resolution

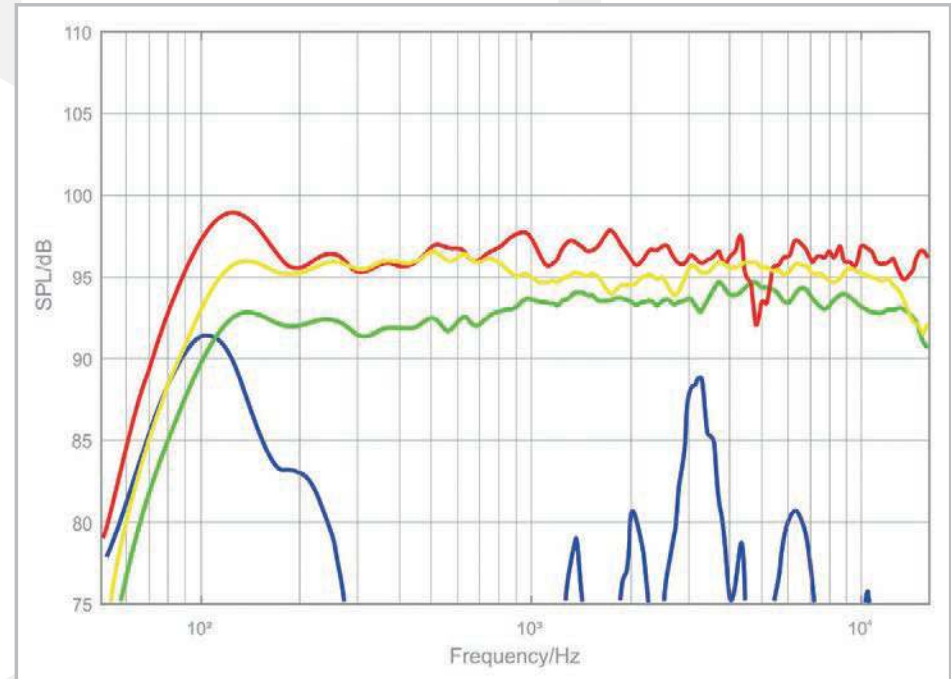

Rejection behind speaker

Front Row

Mix Position

Back row



MODULAR DESIGN

Each O-Line array is constructed by connecting together multiple array modules. Up to 24 modules can be connected where both high output and vertical focusing down to low/mid frequencies are required. Smaller numbers of modules (down to 4) can be used for shorter-throw applications, where vertical focussing of the low/mid frequencies is less important. This scalability means that O-Line can be used in an extremely wide variety of applications – from bars and restaurants to sports venues, churches and railway concourses.

A passive two-way system, each module consists of 2 x 3 ½” (87mm) low/mid radiators either side of a central strip of 5 x 0.55” (14mm) miniature HF devices on a 100° horizontal waveguide. The horizontal constant-directivity characteristics are maintained down through the midband by the very close physical spacing of the low/mid drivers, whose sculpted, stiff and ultra-light cones follow the contours of the waveguide walls – avoiding wall-cavity effects and contributing to the flawless 100° horizontal constant-directivity pattern.

An internal 2.5kHz passive crossover in each module divides the audio input between the LF and HF sections.

SIDELobe-FREE HF

O-Line uses a line of five custom-designed HF dome tweeters, with a spacing of only 0.83” (21mm) between each device. Such small spacing relegates high frequency vertical sidelobes to outside the audio band.

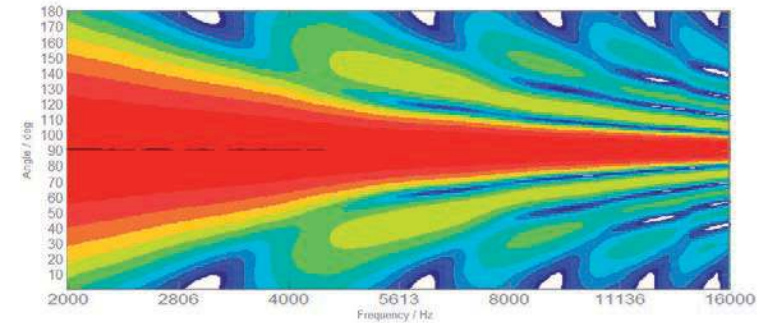

Compare this to using off-the-shelf 1” (25mm) dome tweeters. Sidelobes as loud as the main (red) lobe appear at frequencies as low as 8kHz; well within the audio band!

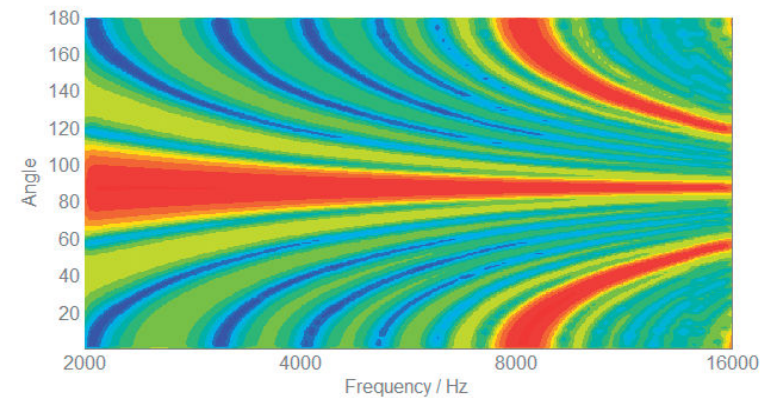

HIGH OUTPUT CAPABILITY

O-Line is capable of surprisingly high output for its size, even though it uses small, direct radiators rather than compression drivers to produce high frequencies. High output is possible because there are five HF devices in each module – resulting in an effective HF voice coil diameter of 3 inches (75mm) with a corresponding increase in power handling. This is important, since it is the HF section in a line array that has the most demanded of it, due to increased air absorption at high frequencies.

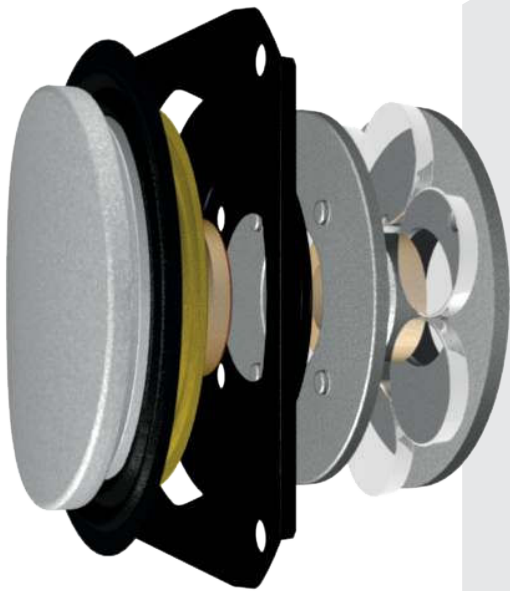

ARRAY CONSTRUCTION AND DEPLOYMENT

Inter-cabinet angles of 0° to 5° are set in 1° steps via rear-mounted link plates and link pins. Rear covers maintain the sleek, unobtrusive appearance required of an architectural loudspeaker product.

Arrays can be wall mounted or flown via optional brackets. They are designed to be unobtrusive and adaptable in order to blend in with their environment. Up to 16 cabinets can be wall mounted using the optional brackets. Pan and tilt are easily achievable. Arrays can be panned left or right and then the bracket locked in position. Tilt is achieved by setting the length of a wire rope or chain 'pull-back' strap, allowing accurate on-site adjustment of array aiming. The brackets are designed as 1st/2nd fix components in accordance with typical installation methods.





SUMMARY

Award-winning O-Line installations are testament to its ability to deliver high-quality, full-range sound in challenging acoustic environments. It can be operated in two modes — uniform drive or with scalable resolution up to individual enclosure drive, depending on the specific application requirements. With inter-cabinet splay angles determined by DISPLAY optimisation software, and exceptional performance guaranteed by the acoustic design itself, uniform drive using a single amplifier channel, plus simple EQ and limiting, will deliver outstanding results. When faced with the most difficult acoustic spaces, it can be teamed with an iK81 amplifier, or combination of VIA2004 amplifier and DX4.0 controller, to independently control and power each individual enclosure and access DISPLAY's full capabilities to further fine-tune coverage consistency and keep sound away from reflective surfaces even more.





“ O-Line has a very small footprint, so you hardly know the speakers are there

Ian Fritzsche, South-eastern University
Lakeland, FL, USA



“ I was impressed at how good, how articulate, and how natural O-Line sounded in this space

Jim Messinger, Brown Sound
Holy Rosary Church – Syracuse, NY, USA

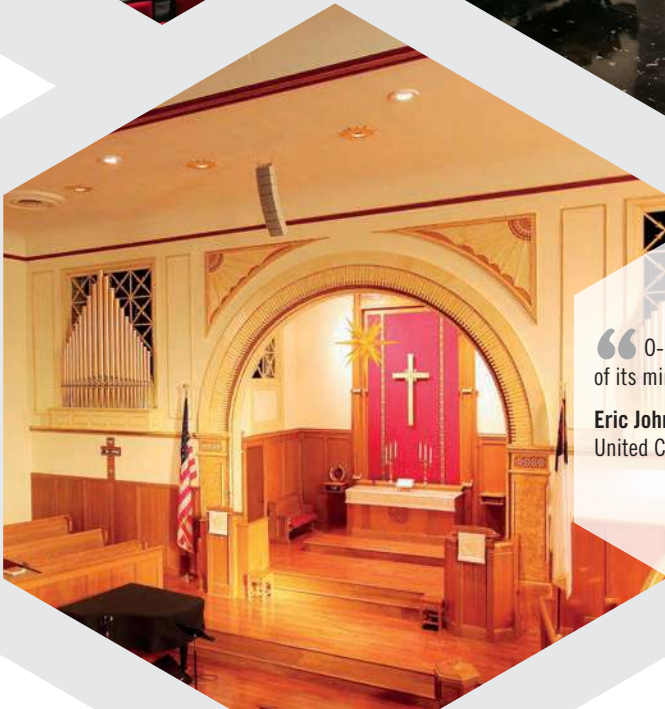

“ O-Line was our first choice simply in terms of its minimal footprint and aesthetic appeal

Eric Johnson, Audio-Video Group
United Church of Christ – Middletown, MD, USA



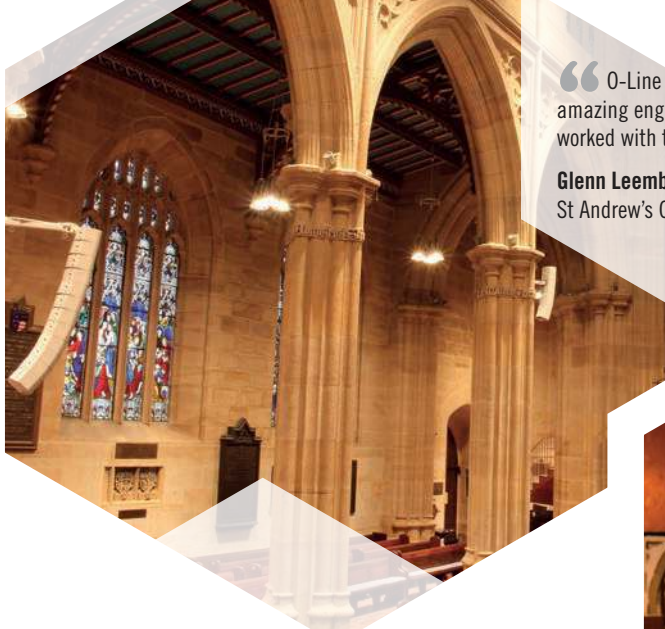

“ O-Line amazes every time we use it; it's an amazing engineering feat. There is nothing I have ever worked with that comes close to this product

Glenn Leembruggen, Consultant Acoustic Directions
St Andrew's Cathedral – Sydney, Australia



“ The results were stunning. With the control afforded by O-Line, we have been able to achieve musical clarity and speech intelligibility

Mark Hanson, Hanson Associates
Temple Beth Israel – Melbourne, Australia

“ O-Line is a night and day difference from what they had before in terms of the coverage and audio quality

Lee Buckalew, TSI Global
Brauer Hall – St Louis, MO, USA



“ The results were jaw dropping!

Jon Perdue, Brigham Young University
Rexburg, ID, USA

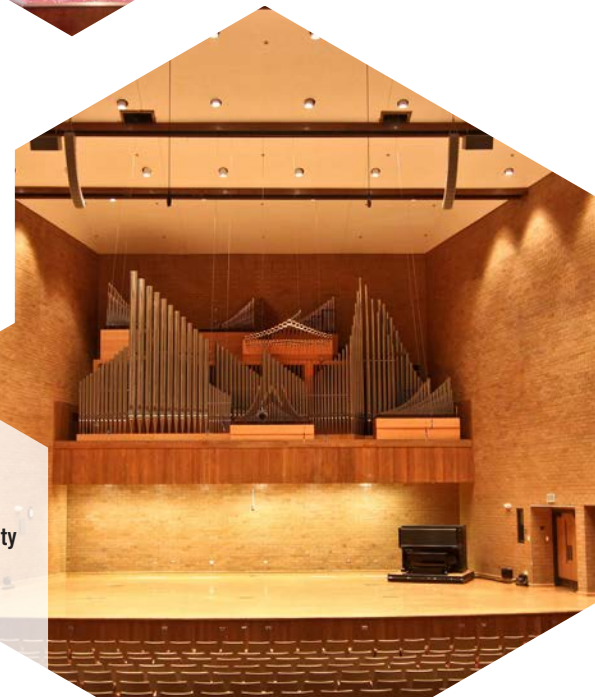

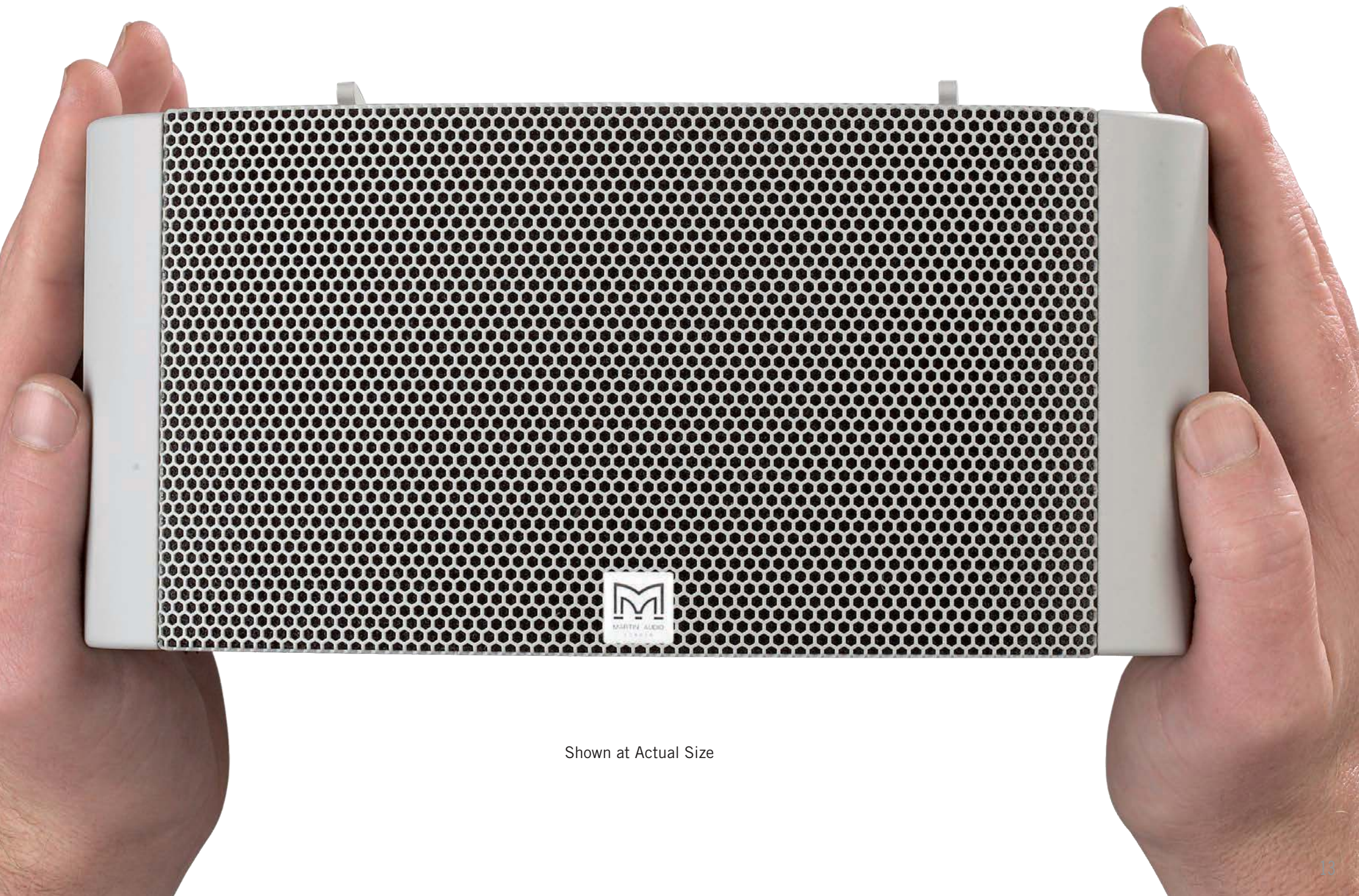

Shown at Actual Size

ACCESSORIES



ASF20021 — O-LINE 4 MODULE WALL BRACKET ASSEMBLY



ASF20022 — 4 TO 16 BOX WALL BRACKET



ASF20023 — O-LINE FLYING BRACKET ASSEMBLY



COV00001 — O-LINE BOTTOM PLATE

TECHNICAL SPECIFICATIONS

O-LINE – ONE MODULE

TYPE	Two-way micro-line array module
FREQUENCY RESPONSE (5)	85Hz-20kHz ± 3dB -10dB @ 76Hz
DRIVERS	2 x 3.5" (87mm)/1" (25mm) voice coil LF drivers 5 x 0.55" (14mm) soft dome tweeters
RATED POWER (2)	50W AES, 200W peak
RECOMMENDED AMPLIFIER	iK81 or VIA2004 (with DX4.0 controller)
SENSITIVITY (6)	84dB at LF rising to 92dB at HF
MAXIMUM SPL (7)	104dB continuous, 110dB peak
NOMINAL IMPEDANCE	16 ohms
DISPERSION (-6dB)	100° horizontal, 5° vertical
CROSSOVER	2.5 kHz passive
ENCLOSURE	4 litre ported cabinet, moulded in ABS
FINISH	Light grey
PROTECTIVE GRILLE	Light grey perforated steel
CONNECTORS	4 pole socket
PIN CONNECTIONS	+/- in, +/- link out
FITTINGS	Captive inter-connecting bracket assembly 6 x M8 fixings for wall and flying brackets
DIMENSIONS	(W) 246mm x (H) 115mm x (D) 198mm (W) 9.7ins x (H) 4.5ins x (D) 7.8ins
WEIGHT	3.6kg (7.9lbs)

Notes

- (1) Measured on-axis in half (2pi) space at 2 metres, then referred to 1 metre.
- (2) AES Standard ANSI S4.26-1984.
- (3) Measured in half (2pi) space at 2 metres with 1 watt input, using band limited pink noise, then referred to 1 metre.
- (4) Measured in half (2pi) space at 2 metres using band limited pink noise, then referred to 1 metre.
- (5) Measured on-axis in open (4pi) space at 2 metres, then referred to 1 metre.
- (6) Measured in open (4pi) space at 2 metres with 1 watt input, using band limited pink noise, then referred to 1 metre.
- (7) Measured in open (4pi) space at 2 metres using band limited pink noise, then referred to 1 metre.
- (8) Measured in open (4pi) space at 2 metres with 2.83v input, using band limited pink noise, then referred to 1 metre.
- (9) Calculated at 1 metre.
- (10) Measured in half (2pi) space at 2 metres with 2.83V input, using band limited pink noise, then referred to 1 metre.

O-LINE – ARRAY

NO. OF MODULES	4	8	16
SENSITIVITY (6), (2.83V)	96dB	96dB	102dB
IMPEDANCE	4 ohms	8 ohms	4 ohms
POWER HANDLING (WATTS, AES)	200 cont. 800 peak	400 cont. 1600 peak	800 cont. 3200 peak
MAXIMUM SPL (CONT./PEAK)	116dB/122dB	122dB/128dB	128dB/134dB
MAX COVERAGE DISTANCE	8-12m	16-25m	25-40m
ARRAY LENGTH	0.47m	0.94m	1.9m
ARRAY MASS	14.4kg	28.8kg	57.6kg

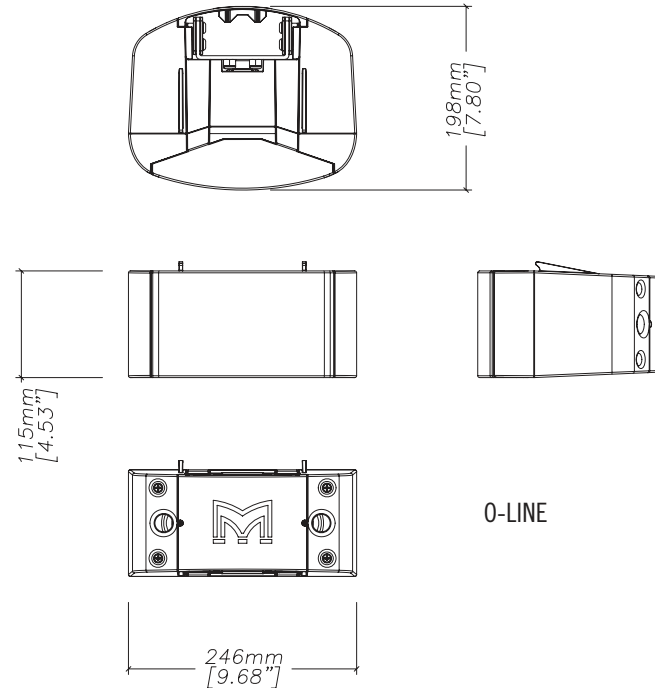

O-LINE

O-LINE™

MICRO LINE ARRAY

NOW WITH SCALABLE RESOLUTION

Martin Audio Limited

Century Point
Halifax Road
Cressex Business Park
High Wycombe
Buckinghamshire
HP12 3SL
England

FOR SALES ENQUIRIES:

UK

Telephone: +44 (0)1494 535312
E-mail: info@martin-audio.com

NORTH AMERICA

Telephone: 818 649 7776

www.martin-audio.com

Version 2.1

All information is Copyright © 2018 Martin Audio Ltd.

Martin Audio, the Martin Audio logo and Hybrid are registered trademarks of Martin Audio Ltd. in the United Kingdom, United States and other countries; all other Martin Audio trademarks are the property of Martin Audio Ltd.



Unite Your Audience
The Martin Audio Experience

