



LE

STAGE MONITORS

A LEGEND IS REBORN



Unite Your Audience
The Martin Audio Experience





The stage monitor plays a key role in creating an onstage environment that connects performers to the audience. Martin Audio's first LE monitor led the way to become the industry standard in the early 1970s, and LE monitors have continued to make their presence felt in the decades since. Complementing Martin Audio's state-of-the-art, high-performance XE Series monitors, the latest LE Series now brings engineering innovation to everyday stage monitoring — delivering exceptional performance and controlled coverage at a price point not previously possible for a truly professional monitor.

Both the LE100 and the LE200 are designed for a wide range of users and applications — from up-and-coming bands and regional rental houses, to corporate AV events, HoW and fixed installations.

With extremely compact enclosures and unique CDD™ Coaxial Differential Dispersion technology, the LE Series monitors deliver cut-through sound with a coverage pattern that allows performers greater freedom of movement compared to conventional monitors. Instead of the typical 'hot-spot', they produce a near-rectangular coverage pattern over a listening plane at head-height — with a wide horizontal coverage close to the monitor that reduces gradually as distance increases to maintain consistent SPL and tonal balance.

Professional and affordable, the latest LE Series puts great sound, optimised coverage and the very latest in innovative monitor technology literally at your feet.

LE Series: A Legend is Reborn





FEATURES

- Compact, two-way stage monitors
- Coaxial 'point-source' performance
- Differential Dispersion™ technology for consistent coverage
- Defined, near-rectangular coverage plane at head-height
- Switchable active/passive operation (LE200)
- Low-profile plywood enclosures
- Integral pole-mount with removable bung (LE100)
- M8 rigging inserts
- Multiple connectors for flexible deployment

APPLICATIONS

- Stage monitor
- Pole-mounted fill/PA system (LE100)

COAXIAL DIFFERENTIAL DISPERSION™: THE PERFECT COMPACT MONITOR TECHNOLOGY

LE Series monitors feature Martin Audio's unique, patented Coaxial Differential Dispersion drivers to deliver perfect monitor sound over a controlled area. Coaxial Differential Dispersion technology combines the 'point-source' benefits and compact format of coaxial designs with the consistent coverage of Differential Dispersion technology.



- LE200

THE COAXIAL ADVANTAGE

Non-coaxial two-way monitors can suffer from uneven frequency response as the artist moves off-axis because the outputs of the LF and HF sections interfere with each other, causing cancellations off-axis, depending on the listening position. This is most noticeable close to the monitor in the all-important crossover region — which lies right in the middle of the vocal band.

In contrast, coaxial monitors can achieve 'point-source' summation of the LF and HF sections at all positions off-axis, even close-up. And, in terms of important practicalities, coaxial designs remove the need for left and right-handed versions and are inherently very compact.

Up to now, a significant disadvantage of conventional coaxial devices has been high frequency beaming — where the high frequency dispersion reduces as the frequency increases. This is primarily because conventional coaxial devices channel high frequencies through a narrow tube in the pole-piece of the magnet system. LE Series coaxial drivers overcome this by incorporating an innovative static waveguide that merges seamlessly with the unique cone shape — maintaining the dispersion pattern out to very high frequencies.

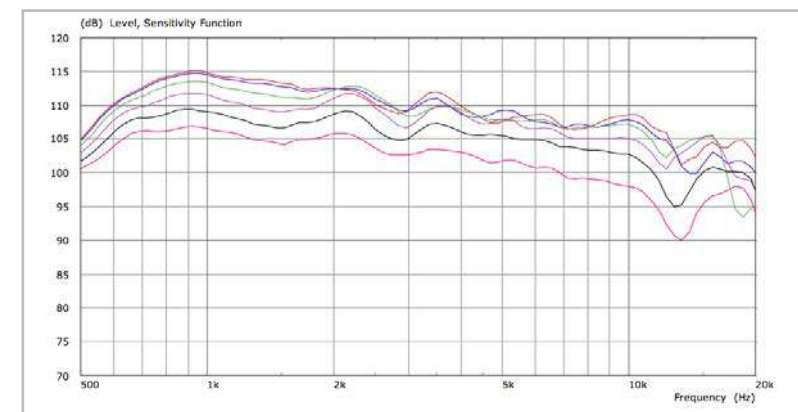

- 0/10/20/30/40/50 degree off-axis horizontal HF response (wide-axis). Constant beamwidth maintained up to 20kHz.

THE DIFFERENTIAL DISPERSION™ ADVANTAGE

A Differential Dispersion horn has a 3D trapezoid dispersion pattern which distributes sound over a plane at the artist's head-height more evenly than a system with a conventional, fixed-dispersion $X^\circ \times Y^\circ$ type horn, which produces an imperfect coverage pattern which misses out some areas — particularly either side off-axis close to the monitor.

LE Series monitors produce a well-defined coverage pattern at head-height with wide horizontal coverage when standing very close to the monitor. Further back, the dispersion progressively narrows, increasing the SPL to compensate for the increased distance from the monitor. The frequency response is unchanged, so the artist hears essentially the same sound balance and level wherever they stand within the coverage area. This consistency in frequency response and SPL — both close to the monitor and further back — is exceptional.

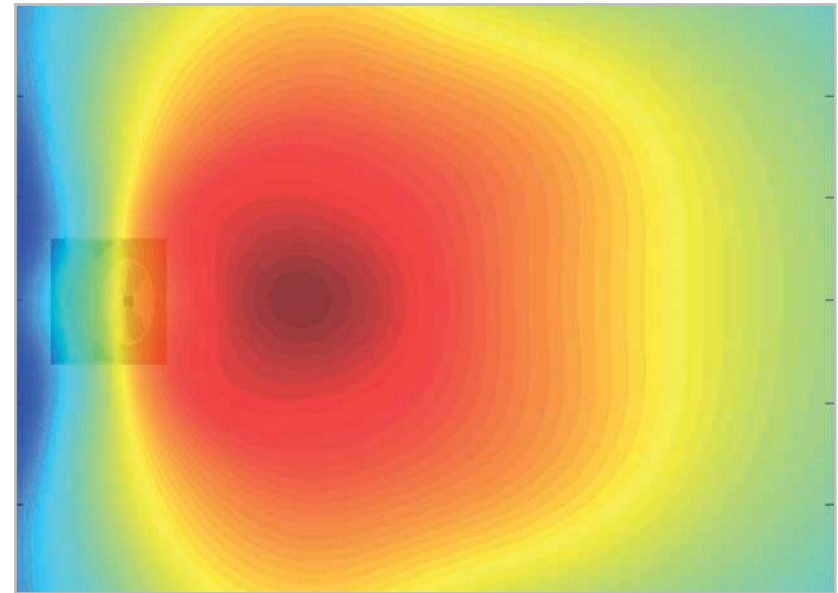

- LE200 SPL @ 4.5kHz over a 3 x 4m plane at head height
Each contour represents 0.2dB change; yellow is -6dB

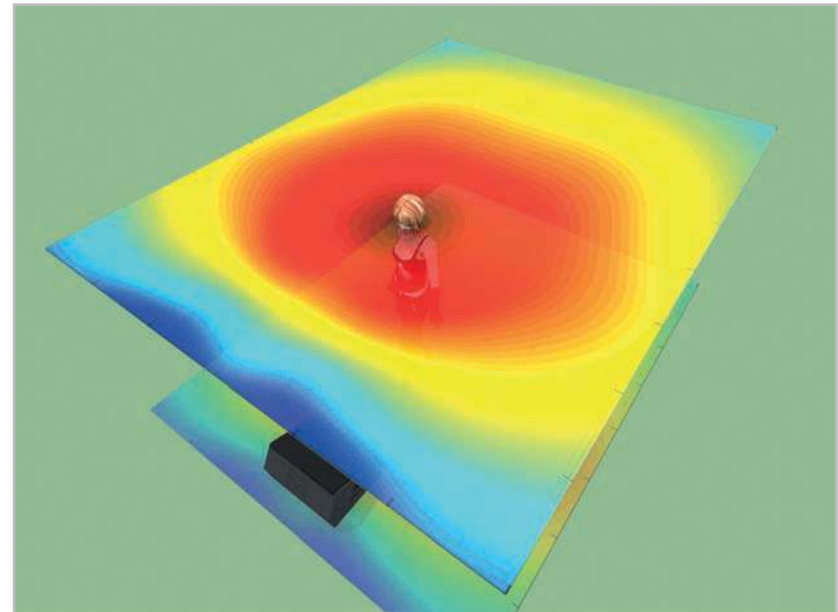

- Near-rectangular coverage
Artist can move freely without significant change in SPL



LE100

The LE100 is an extremely compact, two-way passive monitor. It features a 12" (300mm) LF /1" (25mm) exit HF Coaxial Differential Dispersion driver to distribute sound evenly over the listening plane. The LF driver section has a 2.5" (65mm) voice coil and an efficient motor system with an aluminium demodulating ring to minimise distortion. The coaxial HF driver utilises a 1.75" (44mm) polyimide dome and features a low-compression phase-plug to reduce non-linearity associated with overly-high compression ratios.

The unique Coaxial Differential Dispersion technology employed in the LE100 produces a horizontal coverage pattern which varies from a wide 110° directly over the monitor, reducing to 60° further back. This tapering produces a near-rectangular coverage plane at head-height to maintain the sound level and balance independent of distance from the monitor.

The LE100 enclosure is constructed from durable plywood and is finished with a durable black textured paint. Ergonomic pocket handles assist handling and a strong, perforated steel grille with an acoustically transparent cloth backing provides driver protection. Moulded feet prevent movement onstage and protect the base of the monitor from scratches.

As well as use as a stage monitor, the LE100 offers a range of flexible deployment options. It can be inverted and used as a pole-mounted sidefill or sound reinforcement system without the need to rotate the drive unit, or combined with a Martin Audio subwoofer as a drumfill. A removable pole-mount bung maintains clean lines in stage monitor guise while a total of five NL4 connectors at the front, base and in each handle pocket satisfy a wide variety of user configurations.

LE100



LE200



LE200

Combining very high output capability with Martin Audio's signature sonic performance and consistent coverage, the LE200 is the ultimate, everyday professional monitor. Its Coaxial Differential Dispersion drive unit comprises a powerful 15" (380mm)/3" (75mm) voice coil LF driver and a 1.4" (35mm) exit HF compression driver with a 3" (75mm) pure titanium diaphragm.

Utilising Coaxial Differential Dispersion technology, the LE200's horizontal coverage varies from 100° directly over the monitor, narrowing to 60° further back. This maintains the sound level and balance independent of distance from the monitor and produces a consistent near-rectangular coverage plane at head-height.

The LE200 enclosure is constructed from durable plywood, features integral ergonomic handles, and is finished with a hard-wearing, black textured paint. A strong, perforated steel grille with an acoustically transparent cloth backing provides protection for the Coaxial Differential Dispersion driver, while moulded feet prevent movement onstage and protect against scratches to the base of the monitor.

Switchable between bi-amp and passive operation, the LE200 incorporates an internal 1.6kHz passive crossover and four NL4 connectors located to suit a variety of user requirements. Compact and easy to manoeuvre, its exceptional performance, high output and consistent coverage makes the LE200 the definitive, affordable professional monitor for a wide range of applications.

LE SERIES VOICING

A stage monitor has distinct sonic requirements and voicing is critical. Firm bass punch is essential to counter the low frequency wash emanating from other sources and the room. The monitor also needs clarity and an element of 'bite' that will cut through without being overly harsh. LE Series monitors have been designed with input from leading monitor engineers to deliver the ideal subjective voicing and coverage characteristics for the widest variety of applications.



SYSTEM CONTROL

While the passive LE100 and LE200 in passive mode can be used without a controller, the EQ and limiter functions of a controller such as the Martin Audio DX0.5 or DX4.0 will maximise their capabilities. When the LE200 is used in bi-amp mode, crossover and EQ functions can be provided by the same DX0.5 or DX4.0



RECOMMENDED AMPLIFIERS

LE100 iK81 or VIA2502 or VIA5002 or VIA5004
LE200 iK81 or VIA5002 or VIA5004





TECHNICAL SPECIFICATIONS

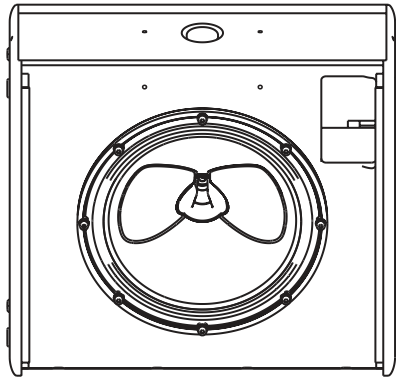

LE100

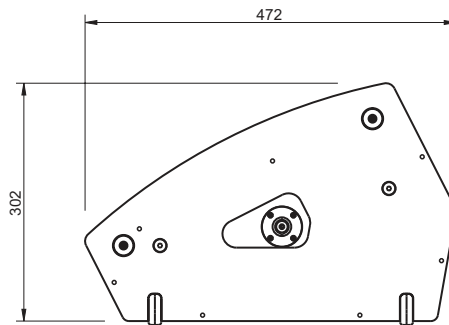
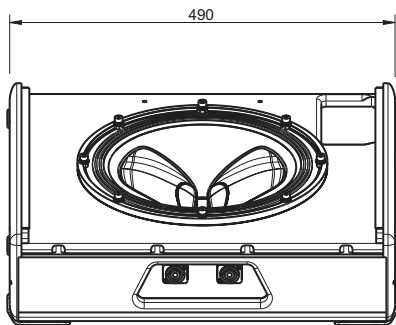

LE100

TYPE	Two-way passive, Coaxial Differential Dispersion stage monitor
FREQUENCY RESPONSE (3)	78Hz-20kHz \pm 3dB -10dB @ 58Hz
DRIVERS	LF: 12" (300mm)/2.5" (63.5mm) voice coil, long excursion, shared ferrite motor system with HF HF: 1" (25mm) exit/1.7" (44mm) voice coil, polyimide dome compression driver
RATED POWER (2)	300W AES, 1200W peak
RECOMMENDED AMPLIFIER	iK81 / VIA2502/5002/5004
SENSITIVITY (3)	97dB
MAXIMUM SPL (9)	129dB peak
NOMINAL IMPEDANCE	8 ohms
DISPERSION (-6dB)	110°-60° horizontal, 60° vertical
CROSSOVER	1.6kHz passive
ENCLOSURE	Birch/poplar ply
FINISH	Black textured paint
PROTECTIVE GRILLE	Black perforated steel with scrim cloth backing
BAFFLE ANGLE	27°
CONNECTORS	5 x NL4 type
PIN CONNECTIONS	1+/1-
FITTINGS	2 x pocket handles Protective rubber feet on base and sides 4 x M8 inserts Pole-mount socket
DIMENSIONS	(W) 490mm x (H) 302mm x (D) 472mm (W) 19.3ins x (H) 11.9ins x (D) 18.6ins
DIMENSIONS INCL FEET	(W) 496mm x (H) 305mm x (D) 472mm (W) 19.5ins x (H) 12.0ins x (D) 18.6ins
WEIGHT	18kg (39.7lbs)
ACCESSORIES	Eyebolts

LE200

TYPE	Two-way, bi-amp/passive Coaxial Differential Dispersion stage monitor
FREQUENCY RESPONSE (3)	68Hz-18kHz \pm 3dB -10dB @ 50Hz
DRIVERS	LF: 15" (380mm)/3" (75mm) voice coil, long excursion, shared ferrite motor system with HF HF: 1.4" (32mm) exit/3" (75mm) voice coil, titanium dome compression driver
RATED POWER (2)	400W AES, 1600W peak
RECOMMENDED AMPLIFIER	iK81 / VIA5002/5004
SENSITIVITY (3)	LF: 100dB, HF: 103dB Passive: 100dB
MAXIMUM SPL (9)	133dB peak
NOMINAL IMPEDANCE	LF/FR: 8 ohms, HF: 8 ohms
DISPERSION (-6dB)	100°-60° horizontal, 60° vertical
CROSSOVER	1.2kHz active/passive (switchable)
ENCLOSURE	Birch/poplar ply
FINISH	Black textured paint
PROTECTIVE GRILLE	Black perforated steel with scrim cloth backing
BAFFLE ANGLE	30°
CONNECTORS	4 x NL4 type
PIN CONNECTIONS	LF/FR: 1+/-, HF: 2+/-
FITTINGS	2 x bar handles Protective rubber feet on base and sides 4 x M8 inserts
DIMENSIONS	(W) 610mm x (H) 364mm x (D) 562mm (W) 24.0ins x (H) 14.3ins x (D) 22.1ins
DIMENSIONS INCL FEET	(W) 616mm x (H) 367mm x (D) 562mm (W) 24.2ins x (H) 14.4ins x (D) 22.1ins
WEIGHT	26kg (57.3lbs)
ACCESSORIES	Eyebolts

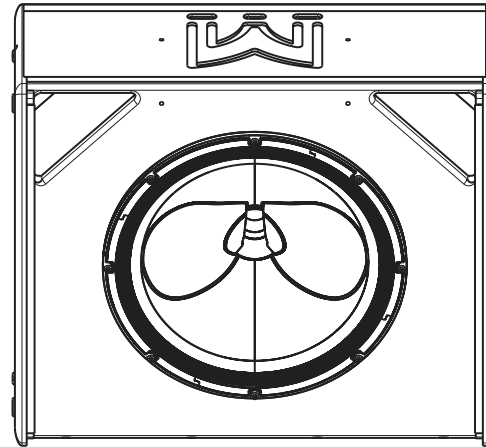

LE200

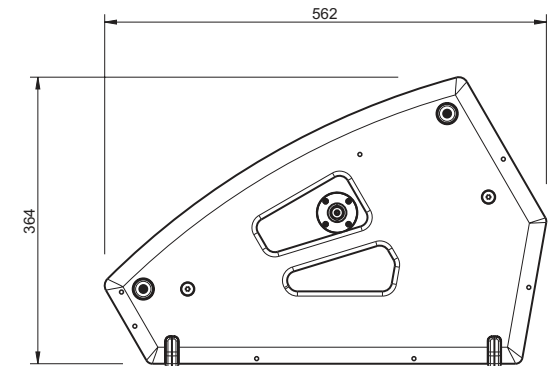
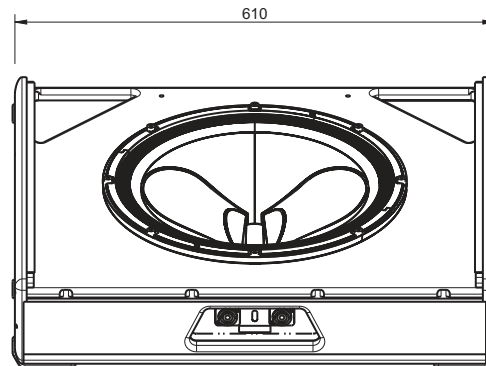

Notes

- (1) Measured on-axis in half (2pi) space at 2 metres, then referred to 1 metre.
- (2) AES Standard ANSI S4.26-1984.
- (3) Measured in half (2pi) space at 2 metres with 1 watt input, using band limited pink noise, then referred to 1 metre.
- (4) Measured in half (2pi) space at 2 metres using band limited pink noise, then referred to 1 metre.
- (5) Measured on-axis in open (4pi) space at 2 metres, then referred to 1 metre.
- (6) Measured in open (4pi) space at 2 metres with 1 watt input, using band limited pink noise, then referred to 1 metre.
- (7) Measured in open (4pi) space at 2 metres using band limited pink noise, then referred to 1 metre.
- (8) Measured in open (4pi) space at 2 metres with 2.83v input, using band limited pink noise, then referred to 1 metre.
- (9) Calculated at 1 metre.
- (10) Measured in half (2pi) space at 2 metres with 2.83V input, using band limited pink noise, then referred to 1 metre.



LE

STAGE MONITORS

A LEGEND IS REBORN

Martin Audio Limited

Century Point

Halifax Road

Cressex Business Park

High Wycombe

Buckinghamshire

HP12 3SL

England

FOR SALES ENQUIRIES:

UK

Telephone: +44 (0)1494 535312

E-mail: info@martin-audio.com

NORTH AMERICA

Telephone: 818 649 7776

www.martin-audio.com

All information is Copyright © 2017 Martin Audio Ltd.

Martin Audio, the Martin Audio logo are registered trademarks of Martin Audio Ltd. in the United Kingdom, United States and other countries; all other Martin Audio trademarks are the property of Martin Audio Ltd.



Unite Your Audience
The Martin Audio Experience

Version 1.1