



MULTI-CELLULAR LOUDSPEAKER ARRAY





Martin Audio has a rich history, pioneering high-efficiency touring sound systems since the 1970's.

Driven by research, Martin Audio's latest developments — first seen in the MLA[®] system — combine ground-breaking cellular array design with fast, automated intelligent software to deliver a dramatically increased level of performance and coverage consistency compared to conventional line array technology.

In the short time since its introduction, MLA has received multiple awards for innovation. Now, MLA Compact[™] brings the revolutionary cellular technology behind MLA to a wider range of touring and installed sound applications.





▲ MLA: Royal Albert Hall, London



▲ MLA: United Center, Chicago



▲ MLA: Philips Arena, Atlanta

THE CELLULAR REVOLUTION BEYOND LINE ARRAY

Every so often a new technology renders previous technologies obsolete, or relegates them to the second-tier. Just as line array took over from point-source systems to become the touring standard over the last decade, in 2010 Martin Audio's MLA® Multi-cellular Loudspeaker Array introduced a revolutionary new technology to touring sound.

MLA's combination of cellular drive and fast, automated optimisation software delivers the engineer's mix throughout the venue with an accuracy and consistency simply not achievable with traditional line arrays.

Unlike line arrays — which aim to produce iso-phasic wavefronts as they exit from the array (usually up in the air in real-world applications) — MLA cellular technology is designed to achieve phase-coherent summation across the audience itself. MLA technology holds both frequency response and SPL within a very tight, user-specified window — from the front rows to the rear balconies.

MLA technology gives the system tech the tools to control sound throughout the venue with absolute confidence, and the FOH engineer can mix knowing that the balance set at the mix position will be heard everywhere.

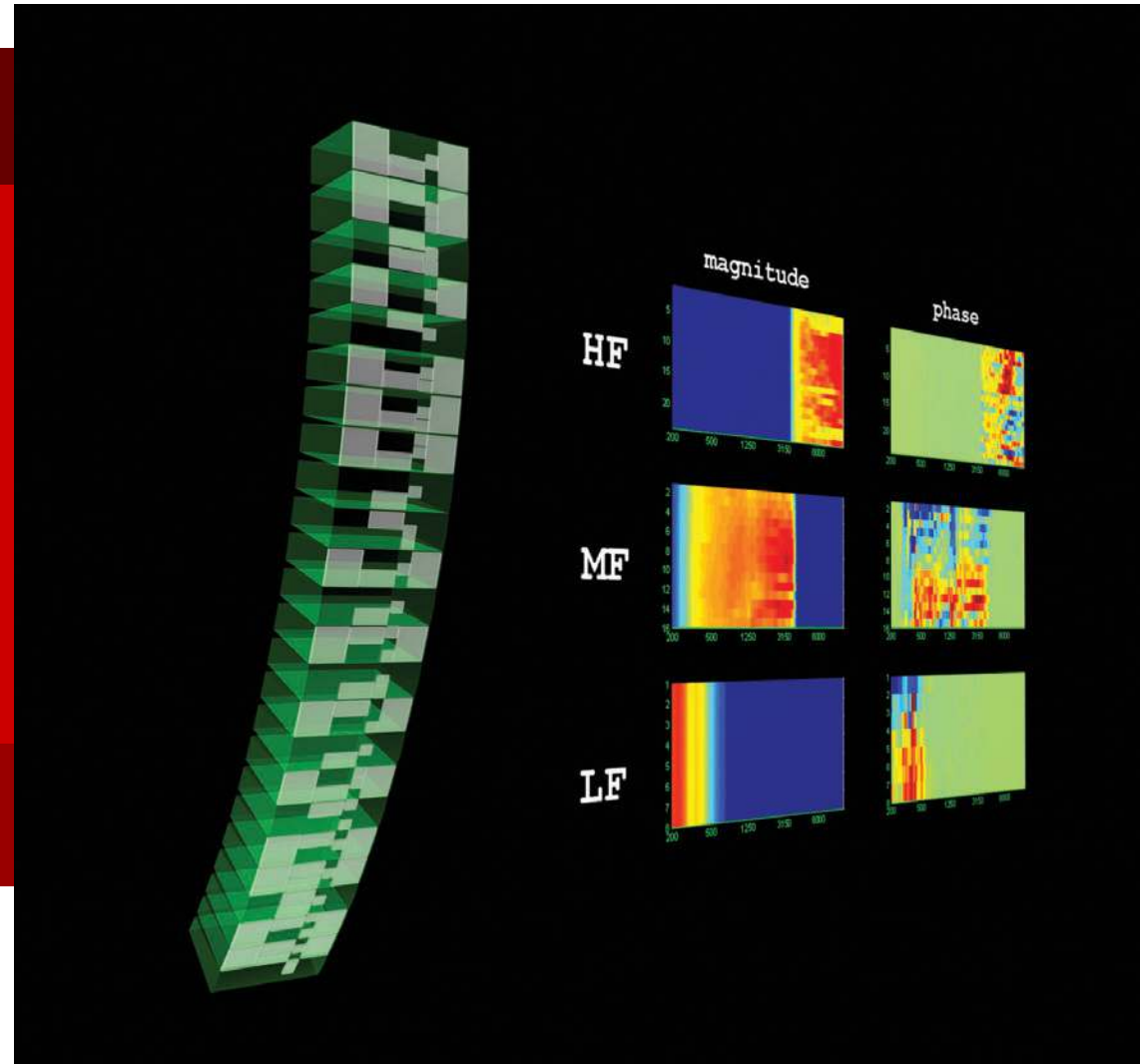

▲ MLA cellular drive

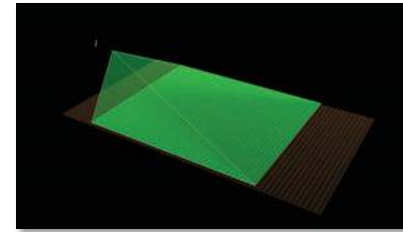

▲ Native array coverage

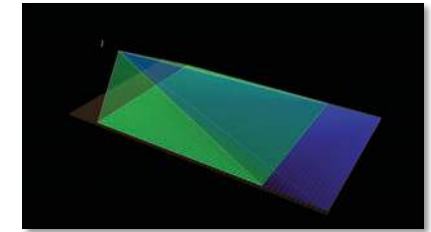

▲ Coverage extended electronically

Measurements of line arrays in the field have shown that SPL and frequency response vary widely at different distances from the array. And setting up a line array remains a trial-and-error process, with preset libraries under constant revision.

MLA cellular technology takes a radically different approach — replacing trial-and-error with automation and an accurate acoustic model. Everything is done from an audience perspective. First, audience and venue criteria are entered into intelligent optimisation software, which calculates exactly what acoustic source is required. Secondly, the software configures an array and calculates the individual DSP parameters for each cell within the array that will generate this source.

As a computer-controlled system, with so many individual cells under software control, vertical coverage can also be adjusted electronically to cope with changing environmental conditions and last minute changes in rigging height. No need to re-rig. “Hard-avoid” areas — such as ceilings, balcony edges, stage areas and venue perimeters — can also be programmed in. Physical fixes, such as balcony bars, are no longer relevant.



▲ Automated optimisation

MLA COMPACT SCALABLE AND VERSATILE



MLA cellular technology is a breakthrough in the way touring loudspeaker systems are arrayed and controlled. In a short time, the flagship MLA has received multiple awards — including the PLASA Gold Award for Innovation, the MusikMesse International Press Award, and the Parnelli Indispensable Technology Award.

Now, the MLA Compact brings MLA technology to the wide range of applications that do not require the full power and throw of the full-size MLA, or where a smaller, lighter system is called for. MLA Compact shares the sonic attributes of the flagship MLA and is designed for medium-scale touring and fixed installations. Its compact size belies its output capabilities — a 12-box array can easily deliver full rock SPL's in a 5000 seat venue, whilst a 24-box array will approach the output of many “full-size” systems which have less efficient acoustic elements.



Scalable and versatile, MLA Compact is the ideal system for ballroom, theatre and HoW applications and is the natural choice as a side-hang or front-fill for the full-size MLA.

**Its compact size
belies its output
capabilities**



MLA COMPACT FEATURES AND BENEFITS

FEATURES

- Numerically optimised, fully-integrated, compact touring sound system
- Cellular array format with built-in amplification, DSP and digital networking
- 5 dedicated Class D amplifier channels per enclosure for individual powering and DSP control of individual cells
- Industry leading DISPLAY2.1 intelligent software interacts with onboard DSP for highly accurate array optimisation. Eliminates trial-and-error array preset library approximations
- "Fly-by-wire" software adjusts vertical coverage electronically to cope with changing environmental conditions and last minute changes in rigging height. "Hard-avoid" areas, such as on-stage, ceilings and site perimeter, can be programmed in
- Switched mode power supplies with PFC (Power Factor Correction) and global mains voltage operation
- Three-way design delivers LF/MF/HF peak SPL's of 135/135/135dB @ 1m from a single, compact enclosure
- Fast, integral flying system for suspension of up to 24 enclosures
- True 100° (-6dB) horizontal constant directivity, mid and high frequency pattern control. Consistent and usable out to 130° (-10dB)
- 65Hz-18kHz \pm 3dB full bandwidth frequency response

BENEFITS

- Desired house-curve achieved right from power-up
- Automatic, intelligent configuration and optimisation eliminates trial and error in system set-up
- Improved venue-to-venue, gig-to-gig consistency and repeatability
- Artistic changes to balance at the mix position (or elsewhere) translate directly and accurately throughout the audience
- Exceptionally high powerdensity means tighter truck-pack for higher SPL compared to other systems
- "Greener" audio power via PFC (Power Factor Correction)
- Programmable leakage parameter to meet environmental noise constraints

APPLICATIONS

- Premium touring sound reinforcement for medium-size venues
- Fixed installations in concert halls, theatres, ballrooms and HoW
- Side hang for MLA festival and arena systems



MLA COMPACT A FULLY INTEGRATED SYSTEM

MLA Compact is a fully integrated system. It brings together the latest technologies in acoustic design, amplification, DSP and industry-leading optimisation software — with communications and control via an easy-to-use audio network. MLA Compact arrays can be remotely controlled from a PC or wireless tablet running VU-NET™ control software.

Class D amplification, U-NET™ control network and DSP circuitry are integrated within each enclosure, simplifying system set-up and operation and eliminating long, heavy-gauge cable runs — a particular benefit in premium fixed installations. Reducing cable runs to just inches within the enclosure means that all the power produced by the amplifier goes directly to the speakers and is not dissipated in the cables.



With MLA Compact, external amplifier racks are dispensed with — saving valuable space both on tour and in fixed installations. From the outset, MLA Compact has been designed with the financial and environmental aspects of running a system in mind; use of maximum-efficiency acoustic and amplifier technologies reduce both the size and weight of the system, assisting transportation as well as reducing the mains or generator power needed to run the system.

**Arrays can be
remotely controlled
from a PC or
wireless tablet**

DRIVEN BY RESEARCH THE ACOUSTIC MODEL

Since it is a practical impossibility to measure every possible array configuration with different combinations of enclosure numbers, splay angles and drive signals, an accurate acoustic model is essential. Without one, attempts to configure and optimise an array will never produce the right answer. Martin Audio's in-house BEM (Boundary Element Method) models enable hundreds of "what-if?" virtual array configurations to be investigated in very fine detail in a virtual 3D environment. This level of research has transformed our understanding of how arrays really work and shown that the acoustic interactions between array elements are much more complex than originally thought.

An important factor and industry first is the inclusion in the model of the previously ignored effects of adjacent enclosures. If these are not incorporated into the model, prediction errors can be over 8dB in the midrange. Including the effect of adjacent cabinets is key to the accuracy of the optimisation process and makes the acoustic model of MLA systems behaviour the most accurate within the industry.

For further explanation on the acoustic model, see S. Feistel, A. Thompson and W. Ahnert, "Methods and Limitations of Line Source Simulation," presented at the 125th Convention of the Audio Engineering Society (2008 Oct.), convention paper 7524).

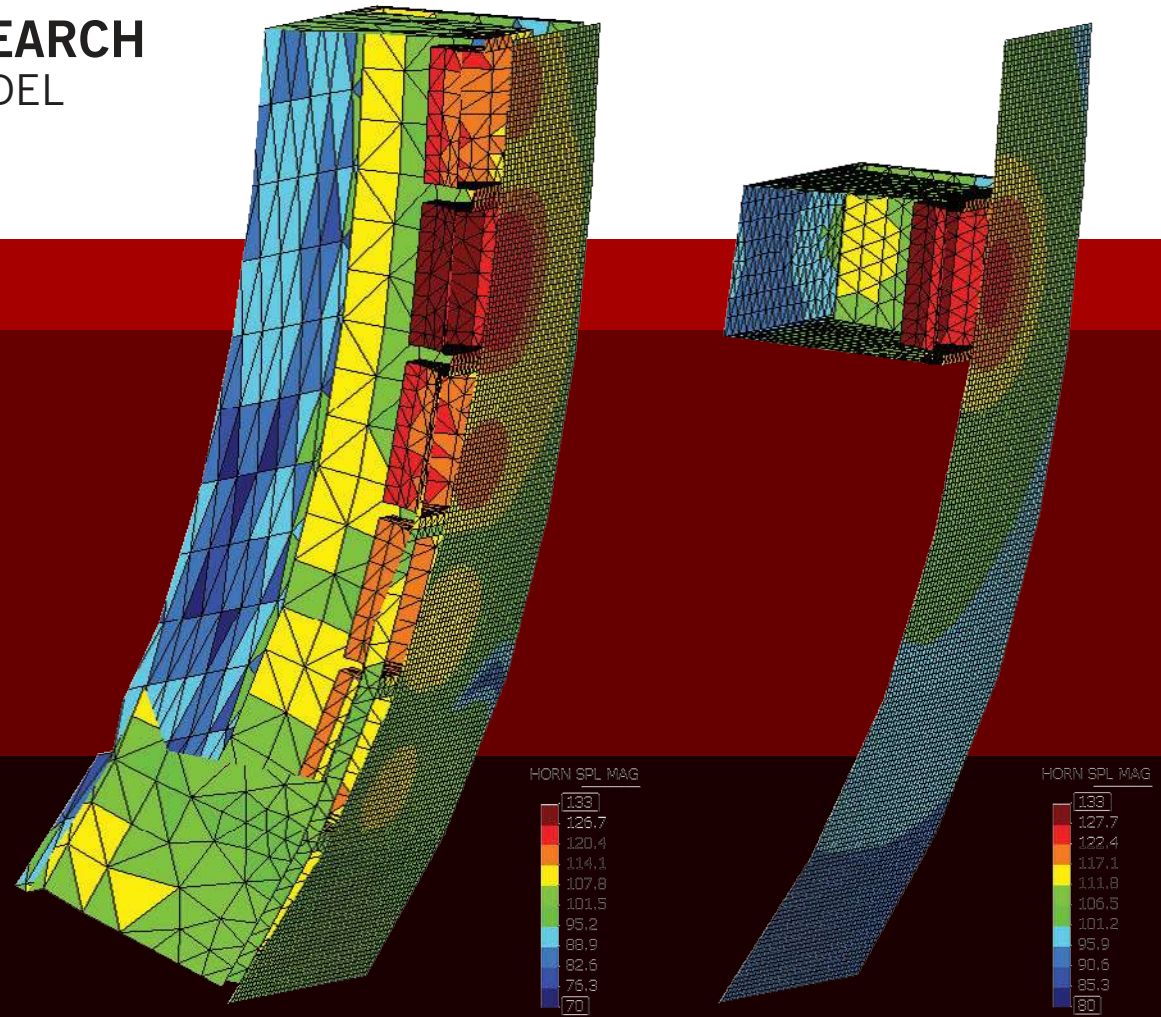

▲ BEM plot of horn in an array

▲ BEM plot of single horn

DISPLAY2.1™ AUTOMATION AND ARTISTIC CONTROL

Current array design software depends on trial-and-error — expecting the user to inspect the results of a trial array, think of something to change, wait... and repeat. Our new software reverses the sequence. Starting with a specified SPL and response over the audience floor, the software works backwards to configure an array that will give the required result.

DISPLAY2.1 is the “brain” of MLA Compact. It provides a virtual environment within which arrays can be configured and optimised — giving a very accurate prediction of the direct sound produced over the audience and also over areas where sound is to be avoided. It takes the guesswork out of array design and deployment — generating highly accurate spot frequency responses and comprehensive rigging information, including mechanical load safety analysis.

DISPLAY2.1 interacts with MLA Compact’s onboard DSP to deliver consistent sound throughout a venue. It calculates the filter parameters for each enclosure — down to the resolution of individual drive units — and uploads them to the enclosure via the U-NET™ digital network. The link between DISPLAY2.1 and an individual MLA Compact enclosure is live and bidirectional.

VENUE ENTRY

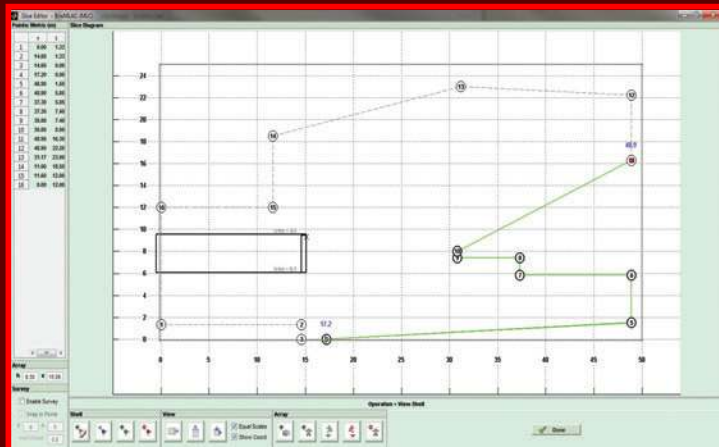

SET COVERAGE PARAMETERS

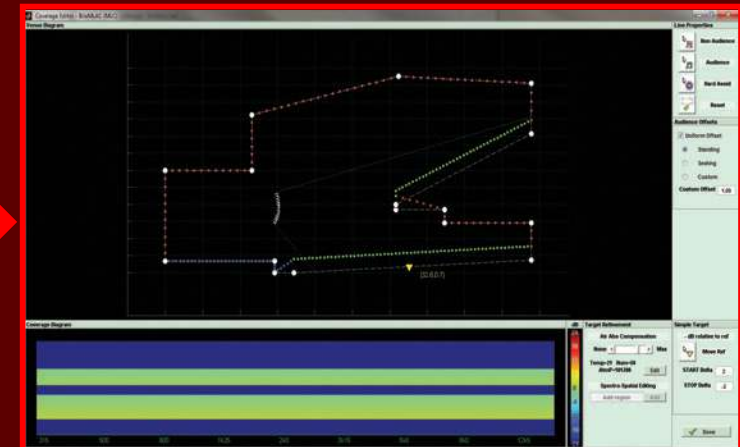

1. Measure the room and enter shell into D2.1
2. Decide how many cabinets
3. Position array
4. Set coverage start and stop

1. Assign audience, non audience and hard avoid areas
2. Set reference position
3. Set front-to-back SPL delta directly in dB's
4. Enter atmospheric conditions and desired compensation

The engineer retains full artistic control over the house curves

DISPLAY2.1's optimisation process starts with a new way of looking at things. Taking a vertical 2D slice through the venue, the frequency response of a candidate array is calculated at 100 or more virtual measuring positions — including the audience areas where the sound is targeted and "hard-avoid" areas where it is unwanted. The results are viewed in IndexPlot™ — a new proprietary 2D presentation format, which shows clearly how loud the array is at all the measuring positions and at all frequencies.

The intelligent optimisation process evaluates configurations of candidate arrays against various target functions — such as frequency response, flatness, and sound leakage into non-audience areas. With the computer working behind the scenes, the engineer retains full "artistic control" over the house curves — the optimisation routines simply replicate what the engineer hears at the mix position through to as many points in the audience as possible.

DISPLAY2.1 can also fine-tune the vertical coverage after rigging. This has great relevance for outdoor festivals where reducing sound-spill offsite is of increasing importance to event organisers and licensing authorities.

CALCULATE SPLAY ANGLES (2-3 MINUTES)

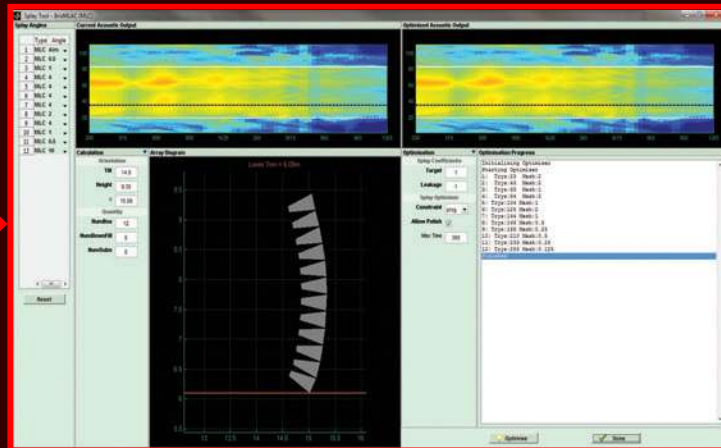

Start to rig arrays

OPTIMISATION AND EXPORT (5-20 MINUTES)



Upload Filter Coefficients

GO

Arrays rigged

1. Automatically calculate the tilt and splay angles
2. Start to rig the arrays

1. Set optimisation targets for non-audience, audience and hard avoid surfaces
2. Automatically calculate filter coefficients — 3200 per MLA Compact enclosure
3. Can now view SPL at any point on the venue shell
4. Export filter coefficients and upload to arrays via VU-NET

MLA COMPACT

ACOUSTIC DESIGN PHILOSOPHY

**MLA Compact
delivers power,
clarity and
detail**



Very compact systems generally use direct radiators for the lows and mids because more efficient acoustic technologies are hard to adapt to small cabinet volumes. MLA Compact's designers have overcome this constraint and raised performance to a new level for such a compact system by applying innovative, slot and horn-loading techniques to the low and mid sections. Sonically, the 3-way MLA Compact delivers power, clarity and detail, with a peak output capability of 135dB LF, 135dB midrange and 135dB HF, per box at 1 metre.

Up to now, with so much attention focussed on the vertical aspects of array behaviour, horizontal dispersion has sometimes been compromised. In common with all Martin Audio touring arrays, MLA Compact deliberately avoids the use of coaxial, co-entrant or cross-firing midrange/HF driver arrangements which introduce acoustic discontinuities that affect the on and off-axis frequency response of both mid and HF sections. In MLA compact, the mid and HF horns are completely separate — a key factor in its ability to produce consistent, true 100° horizontal constant directivity coverage. In use, this translates into startlingly consistent frequency response when listening off-axis and “walking the field”.

MLA COMPACT SLOT-LOADED HYBRID® LF

MLA Compact's LF section utilises 2 × 10" (250mm)/2.5" (63mm) voice coil, neodymium drive units in a unique Hybrid® configuration. Each driver is slot-loaded into a truncated horn with a low flare rate, to give a high sensitivity of 103dB @ 1m/2.83V — whilst the rear of the driver is reflex loaded to extend the LF output. MLA Compact's Hybrid LF arrangement provides the best of both worlds — raising the acoustic efficiency and packing a punch that direct radiators cannot compete with, as well as maintaining the LF extension.

The slot-loading allows the twin LF drivers to be optimally spaced within the enclosure. The double-source arrangement significantly improves the directivity control of the LF section maintaining the 100 degree system beamwidth down to 250Hz and reducing mid-bass output at the sides and rear of the array. The LF drivers themselves are very high excursion with vented poles to reduce power compression and virtually eliminate turbulent air noise.

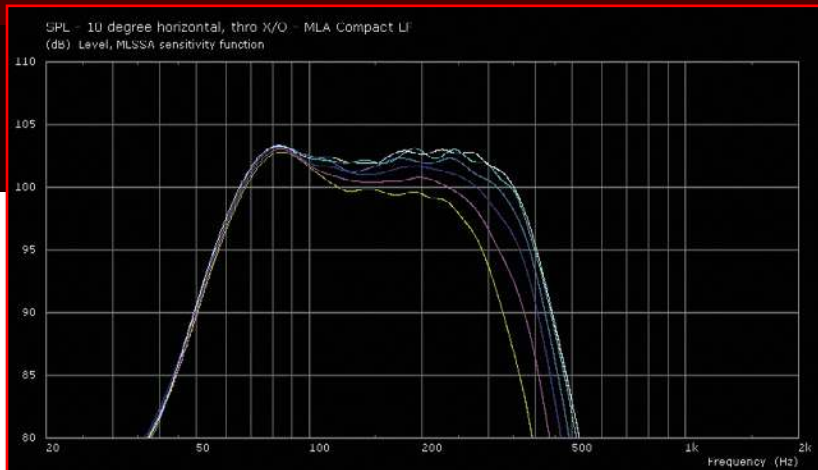

◀ LF horizontal directivity

MLA COMPACT EXEMPLARY MIDRANGE & HF

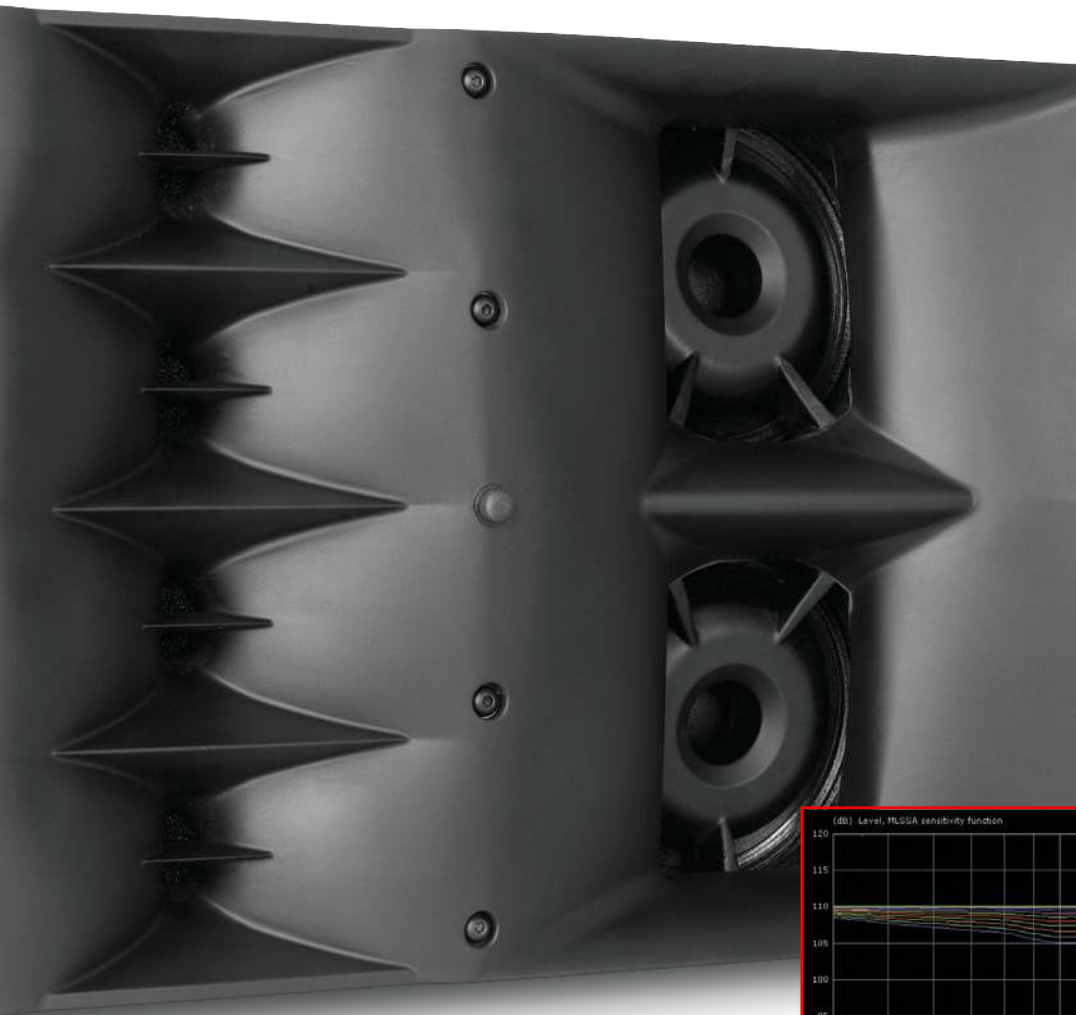

With so much design effort concentrated on the vertical performance of arrays, the horizontal dispersion can sometimes be less than ideal, with dispersion varying at different frequencies — particularly in designs that use coaxial, co-entrant or cross-firing midrange arrangements for the mid/HF. MLA Compact has completely separate, mid and HF horns with horizontal constant directivity characteristics — so the horizontal off-axis response tracks the on-axis response exactly. Martin Audio has over 30 years' experience developing cone-driven midrange horns, and this experience, together with BEM optimised horn geometry has been put to good use in the design of MLA Compact's mid and HF sections.

The mid horn utilises 2 × 5" (125mm)/1.5" (38mm) voice coil neodymium drivers to produce 109dB @ 1m/2.83V — a big gain on the typical efficiency of 102dB for cross-firing direct radiator designs in comparably sized systems. This is a result of painstaking acoustic and thermal design, utilising forced-air cooling and a thermally conductive aluminium housing.

The 9" cone/0.7" compression driver combination replaces the more traditionally used large format compression driver and has less distortion, as well as having a much more extended HF response.

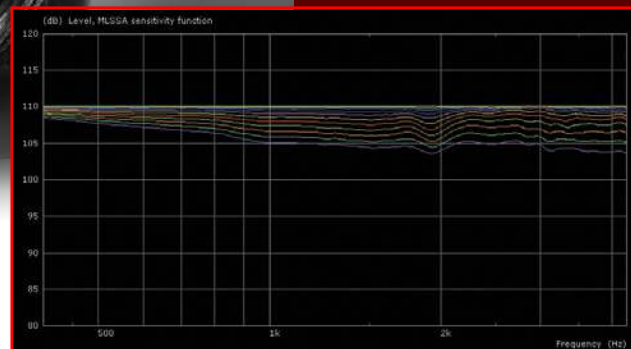

▲ MF horizontal directivity — normalised

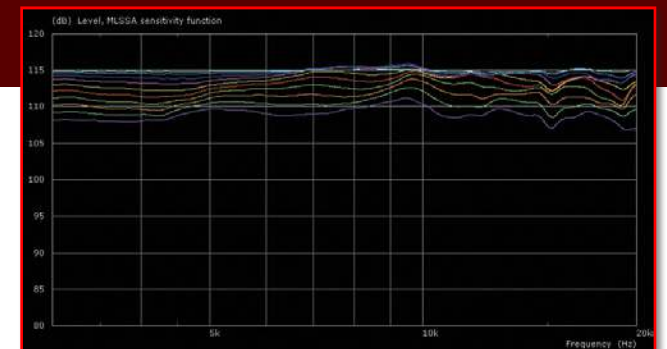

▲ HF horizontal directivity — normalised

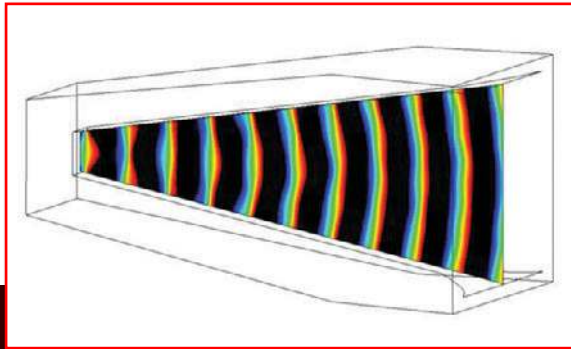

▲ Without wedge: wavefront is too curved

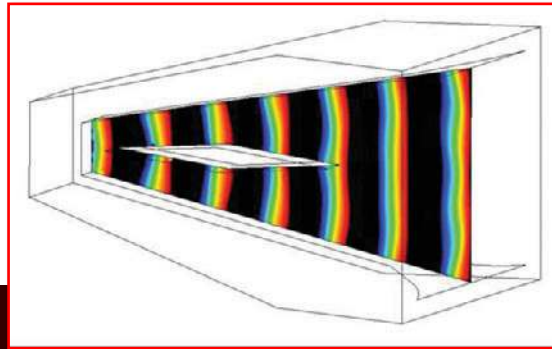

▲ With wedge: curvature is ideally optimised

MLA Compact's HF section utilises 4×0.7 " (19mm) exit neodymium compression drivers which feed separate horns for true 100° horizontal constant directivity. In the vertical plane, MLA Compact makes significant advances over previous thinking by adopting new criteria for vertical wavefront curvature.

Instead of adopting flat wavefronts as advocated by early proponents of touring line arrays, our sophisticated in-house BEM (Boundary Element Method) modelling techniques have shown that slightly curved wavefronts deliver much more consistent SPL's to the audience where the array is curved — as in most practical, real-world applications.

Placing a kite shaped "wedge" part-way down the horn* enables a specific, desired curvature to be achieved — depending on the shape of this wedge. In the case of MLA Compact, the HF wavefront is curved to provide a balance between optimal summation over distance and summation at the maximum inter-cabinet splay angle of 10° .

*Patent GB2446547



Section through HF horns ▶

MLA COMPACT ONBOARD AMPLIFICATION, DSP & NETWORKING

Each MLA Compact enclosure is fitted with a state-of-the-art five-channel amplifier module — with high-efficiency Class D circuitry delivering a total of 2.1kW continuous and 4.2kW peak output. One channel powers both LF drivers in parallel and two channels drive each mid independently. For the HF section, two channels drive the four HF drivers in parallel pairs, making a total of five independently powered acoustic cells per enclosure.

Lightweight, switched-mode power supplies auto-range to global mains voltages from 100 to 240V 50/60Hz, whilst Power Factor Correction smoothes out the mains current draw over the whole of the AC waveform. The amplifier section is designed to withstand rain and ambient temperatures of up to 45°C and features advanced protection — amplifier monitoring via U-NET includes input signal, output signal at the drive unit terminals, limiter status, heatsink temperatures and driver fault conditions.

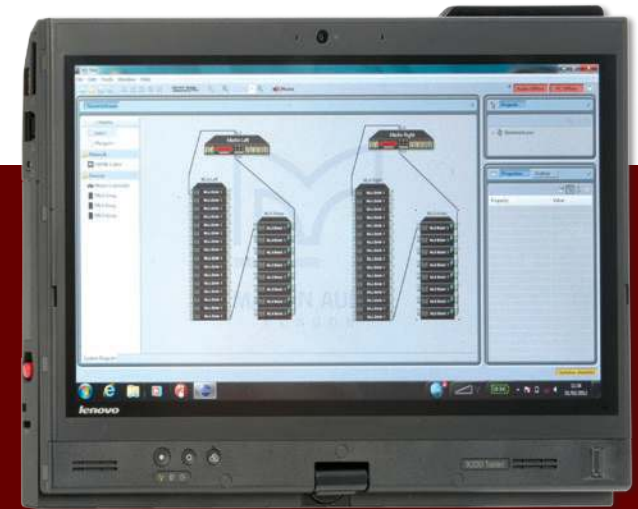

Powerful onboard DSP performs all crossover and EQ functions via a combination of IIR and advanced FIR filtering — fast VanishingPoint™ FIR filters give the freedom to physically separate the mid and HF horns — so they do not compromise each other's constant directivity dispersion pattern — yet achieve the spatial performance of a single device.

Arrays can be remotely controlled over U-NET from a PC or wireless tablet running VU-NET™ control software with its intuitive graphical interface. VU-NET also enables the user to switch on enclosure identification LEDs with automatic identification of neighbouring enclosures and connectivity confirmation.





MLA COMPACT ENCLOSURE AND RIGGING

**MLA Compact's
rigging system
combines speed
with precision**

MLA Compact's rigging system combines speed with precision. Up to 24 enclosures can be suspended via its two-point-lift flybar, and the same hardware can also be used for single point lifting of up to 12 cabinets, as well as ground stacking up to 6 high.

Inter-cabinet connections utilise custom quick-release pins. All loads are borne by the integral metalwork and release pins — not the enclosure. Accompanying software determines the safe limits and tilt angles of a specific array, with BGV C1 safety calculations done on the fly.

The enclosure itself is of birch and poplar ply construction and finished with a thick, hard-wearing polyurea coating. The enclosure sides, which take the brunt of damage on the road, are fitted with replaceable, steel-reinforced rubber mouldings with integral interlocking skids, and an ergonomic bar-handle facilitates rigging and general handling. MLA Compact's are supplied in flightcased pairs, with the flightcase base doubling as the wheelboard for the pair.





MLA COMPACT DSX SUB-BASS

MLA Compact deserves a subwoofer that can match its performance. With an extremely high output level, compact size and advanced DSP-based realisation of directional arrays, the DSX more than meets this challenge.

Capable of 146dB peak output at 1m (half space, measured), the DSX powered and networked subwoofer is an incredible performer. Its high output level is achieved by combining state-of-the-art LF driver technology with an onboard Class D amplifier module which can deliver 6kW peak power.

The DSX features 2 × 18" (450mm)/4" (100m) voice coil, ferrite drivers in a reflex-loaded enclosure with four flared ports, carefully designed to improve linear airflow. Each driver is housed in its own separate chamber to move any cabinet resonances out of band. Sonically, the DSX is a perfect balance of low frequency extension and punch.

A flying version, the DSX-F Sub, can be flown alongside or at the top of MLA Compact arrays, as well as being ground stacked. A maximum of 15 DSX-F can be suspended from the MLA flying frame and symmetrical rigging allows flown DSX-F cabinets to face backwards — enabling directional flown as well as directional ground stacked arrays to be configured.

The ground-stack DSX can be upgraded to the DSX-F by the addition of an easy-to-fit accessory kit.



▲ Flown DSX-F Array

▲ DSX

▲ DSX-F

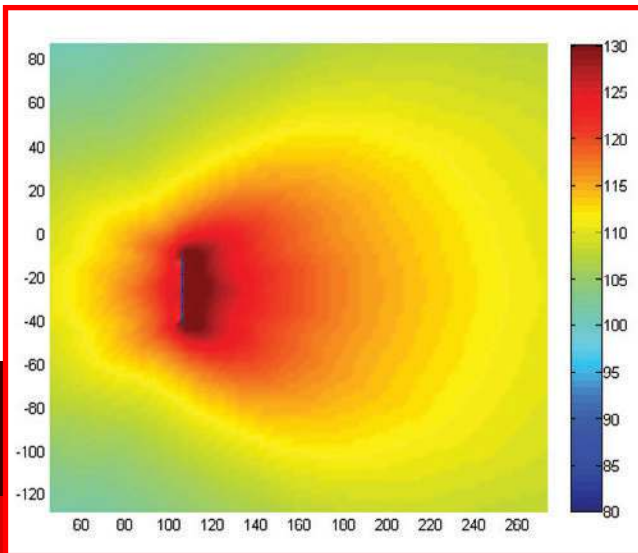

◀ Sub array directivity plot

With Sub-bass directional properties becoming increasingly important, much emphasis has been placed on systems in which each individual enclosure has fixed cardioid properties. This always means sacrificing some frontal energy — even in applications where rear rejection is not necessary. The DSX adopts a less wasteful approach by optimising the directivity of the overall Sub-bass array instead of fixing the directivity of each enclosure. So, whilst an individual DSX Sub is omnidirectional, two or more can be configured into a directional array. This allows you to design in low frequency directivity only when you actually need it and to maximise frontal output even further if you don't.

DSX subwoofer arrays can be designed with specific directional properties and DSP settings uploaded straight into the DSX Subs via the VU-NET network. This goes beyond cardioid — to a world where the forward output, as well as the rear rejection, can be specified and optimised. Cardioid subs were great for the monitor engineer — now, with the DSX, the audience can benefit too.

DSX subwoofer arrays can be designed with specific directional properties

DSX directional ground-stack ▶



MLA COMPACT

SPECIFICATIONS & DIMENSIONS

Acoustical

TYPE	Three-way cellular drive, active array element
FREQUENCY RESPONSE (1)	65Hz–18kHz \pm 3dB
MAXIMUM SPL @ 1m	LF: 129dB continuous, 135dB peak (3) MF: 129dB continuous, 135dB peak (4) HF: 129dB continuous, 135dB peak (4)

Drivers

LF	2 \times 10" (250mm)/2.5" (63mm) voice coil, long excursion, vented pole, neodymium magnet drivers, Hybrid [®] slot-horn loaded
MF	2 \times 5" (125mm)/1.5" (38mm) coil, neodymium magnet drivers, horn loaded
HF	4 \times 0.7" (19mm) exit neodymium magnet compression drivers, horn loaded

Rated Power (2)

LF	500W AES, 2000W peak
MF	180W AES, 720W peak
HF	40W AES, 160W peak

Dispersion

(-6dB)	100° horizontal
(-10dB)	130° horizontal
	10° vertical

Crossover Frequencies

400Hz	8th-order Linkwitz-Riley
4.25kHz	Vanishing Point [™] FIR filters

Audio input

CONNECTORS	Female XLR input, male XLR link output
ANALOGUE INPUT IMPEDANCE	20k Ω balanced to ground
MAXIMUM ANALOGUE INPUT LEVEL	6.15Vrms (+18dBu), over voltage protected
NOMINAL SYSTEM GAIN	22dB
AES/EBU IMPEDANCE	110 Ohms balanced, Receive and transmit termination

Network

CONNECTORS	2 \times IP68 rated 8-way, quick-release type
PROTOCOL	U-NET

Amplifier Module

TYPE	Five channel Class D, fixed frequency
PEAK OUTPUT POWER	4200W
AVERAGE EFFICIENCY	78%
COOLING	2 \times temperature controlled internal fans 1 \times temperature controlled external fan
MAXIMUM AMBIENT TEMPERATURE	45°C (113°F) for full output

Power Supply

TYPE	Switch mode, fixed frequency with PFC
AC INPUT OPERATING RANGE	100 – 240V ~ AC, 50 – 60Hz
POWER FACTOR	> 0.95
NOMINAL POWER CONSUMPTION	600W
MAINS CONNECTOR	16A IEC309 (Ceeform) – IP44 rated (IP67 when mated with mains distribution equipment supplied with system)

General

ENCLOSURE	Vertical trapezoid with 5° wall angle, multi-laminate birch and poplar-ply construction
FINISH	Textured black PU coating
PROTECTIVE GRILLE	Black HEX perforated steel
FITTINGS	Proprietary rigging system Bar handles on each side Protective rubber side-cheeks incorporating skids Weather protection cowl
IP RATING	IP 25
DIMENSIONS	(W) 788mm \times (H) 280mm \times (D) 500mm (W) 31in \times (H) 11in \times (D) 19.7in
WEIGHT	49.5kg (109lbs)
Accessories	Flightcase for two enclosures Flying frame (including clinometer) Ground stacking bar Flying Pin Mains distribution system Tour-grade network interconnects Merlin Controller/U-NET Hub

Notes

- (1) Measured on-axis in open (4 π) space at 4 metres, then referred to 1 metre.
- (2) AES Standard ANSI S4.26-1984.
- (3) Measured in half-space at 6 metres, then referred back to 1m.
- (4) Calculated from 4m 2.83v sensitivity, referred to 1m.

DSX

SPECIFICATIONS & DIMENSIONS

Acoustical

TYPE	Dual 18" reflex loaded subwoofer
FREQUENCY RESPONSE (1)	35Hz–150Hz ± 3dB
MAXIMUM SPL	138dB continuous, 146dB peak (3)

Drivers

LF	2 × 18" 100mm/4" voice coil, ultra-long excursion, high efficiency ferrite magnet
----	---

Rated Power (2)

LF	2400W AES, 9600W peak
----	-----------------------

Dispersion

	Digitally controlled in an array
--	----------------------------------

Audio input

CONNECTORS	Female XLR input, male XLR link output
ANALOGUE INPUT IMPEDANCE	20kΩ balanced to ground
MAXIMUM ANALOGUE INPUT LEVEL	6.15Vrms (+18dBu), over voltage protected
AES/EBU IMPEDANCE	110 Ohms balanced, Receive and transmit termination

Internal Processing

	Single channel DSP, programmable via network
	10 PEQ/shelving filters
	Up to 48dB/Oct HPF and LPF
	Up to 1 second of delay
	Limiters with amplifier output current monitoring

Network

CONNECTORS	IP68 rated 8-way, quick-release type
PROTOCOL	U-NET

Amplifier Module

TYPE	Single channel switch-mode, fixed frequency
PEAK OUTPUT POWER	6000W
AVERAGE EFFICIENCY	85%
COOLING	2 × temperature controlled internal fans 1 × low-speed internal blower
	1 × temperature controlled external fan
MAXIMUM AMBIENT TEMPERATURE	45°C (113°F) for full output

Power Supply

TYPE	Switch mode, fixed frequency with PFC
AC INPUT OPERATING RANGE	100 – 240V ~ AC, 50 – 60Hz

POWER FACTOR	> 0.95
NOMINAL POWER CONSUMPTION	900W
MAINS CONNECTOR	16A IEC309 (Ceeform) – IP44 rated (IP67 when mated with mains distribution equipment supplied with system)

General

ENCLOSURE	Extensively braced multi-laminate birch-ply
FINISH	Textured black PU coating
PROTECTIVE GRILLE	Black HEX perforated steel.
DSX FITTINGS	Two skids on base, with mating channels on top Four interlocking skids on each side Large bar handle on each side Four rear-mounted 100mm (4in) castors DSX transit cover, with integral plywood lid Weather protection cowl
DSX-F FITTINGS	Rear castors replaced by front-mounted wheelboard In addition to DSX fittings, apart from where indicated Four proprietary flying brackets and quick-release pins Side-mounted skids replaced by four interlocking rubber side cheeks DSX-F transit cover, with integral plywood lid
IP RATING	IP 25
DIMENSIONS	DSX (W) 1060mm × (H) 595mm × (D) 834mm (1027mm with vent flap open) (W) 41.7in × (H) 23.4in × (D) 32.8in (40.4in) DSX-F (W) 1125mm × (H) 595mm × (D) 847mm (1027mm with vent flap open) (W) 44.3in × (H) 23.4in × (D) 33.5in (40.4in)
WEIGHT	DSX 122.2kg (269lbs) DSX-F 147.6kg (325lbs) ex. wheelboard

Accessories

	Flying frame, including clinometer (DSX-F)
	Flying Pin (DSX-F)
	Mains distribution system
	Tour-grade network interconnects
	Merlin Controller/U-NET Hub

Notes

- (1) Measured on-axis on ground plane (2π space) at 2 metres, then referred to 1 metre.
- (2) AES Standard ANSI S4.26-1984.
- (3) Measured in half-space at 1 metre with a tone burst signal.

MLA COMPACT

MLA COMPACT & DSX DIMENSIONS

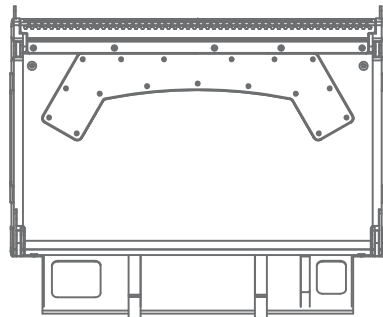
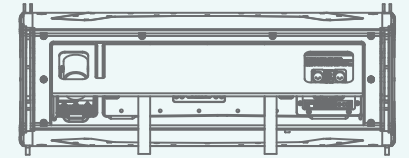
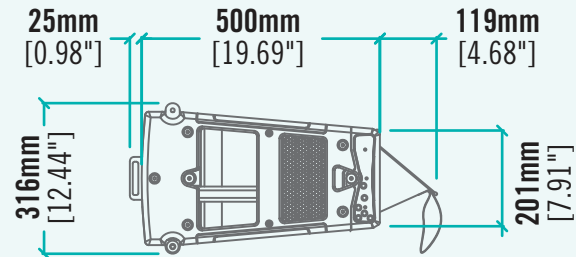
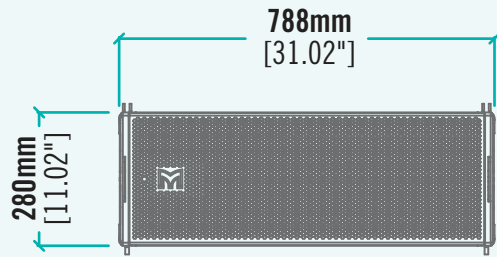
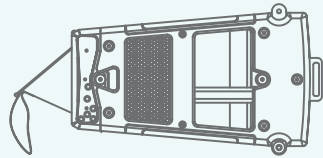
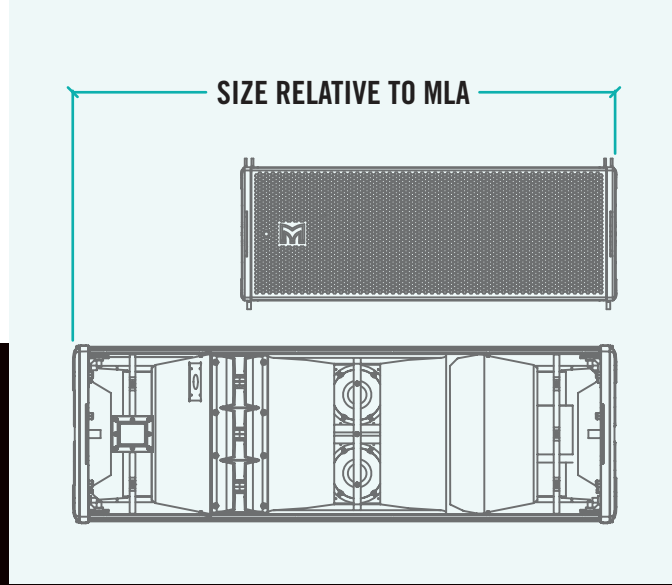
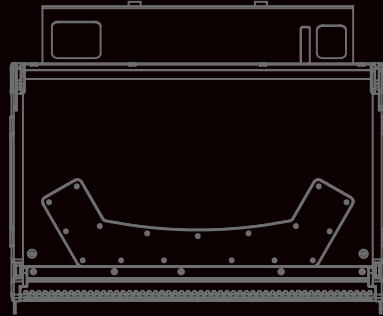

MLA COMPACT

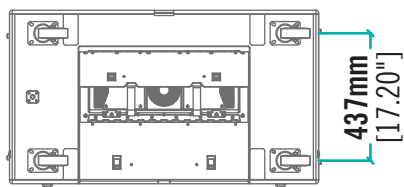
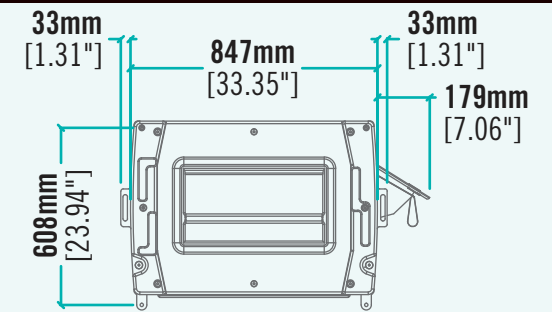
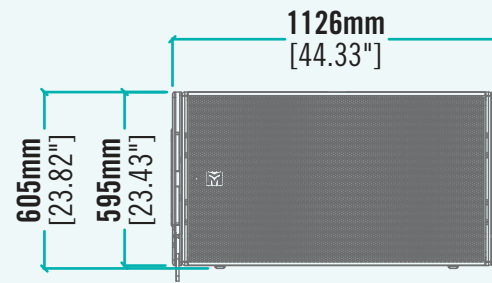
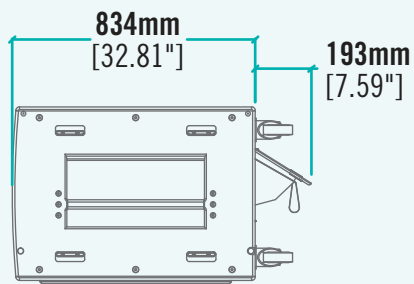
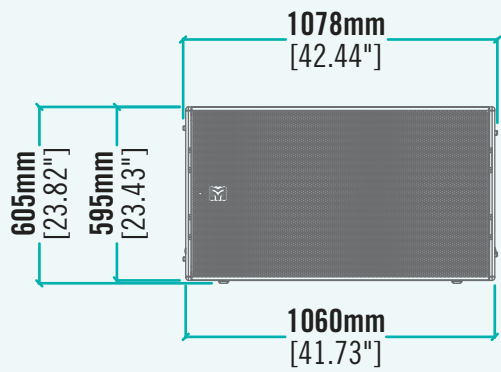
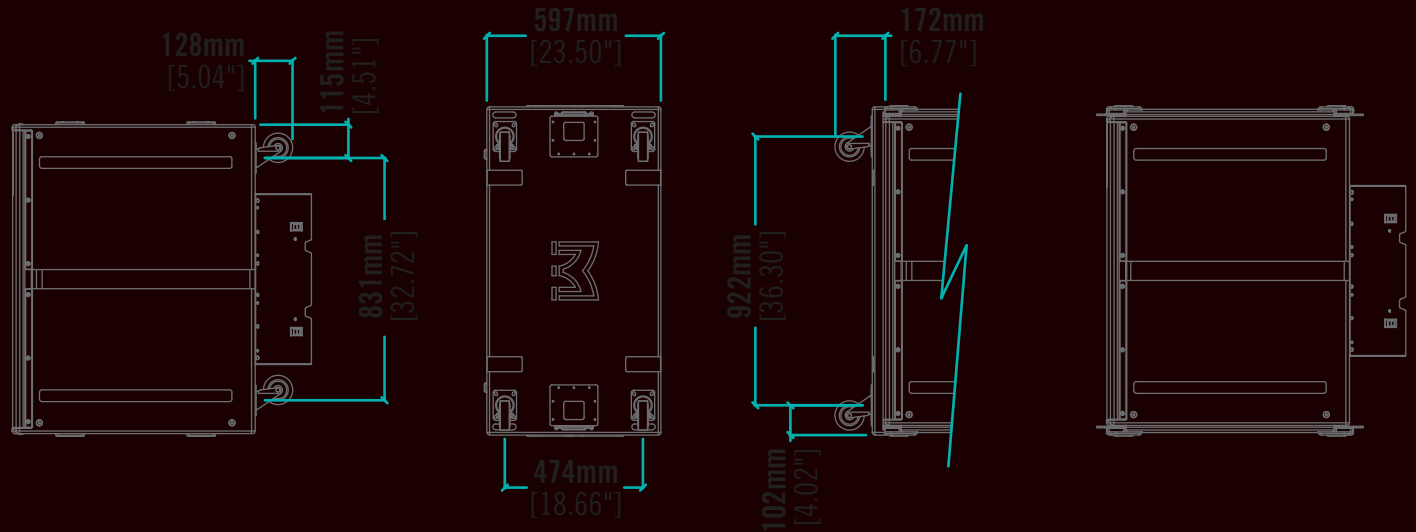

DSX

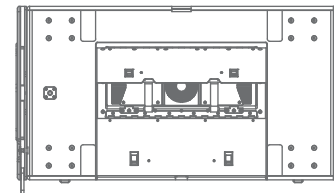
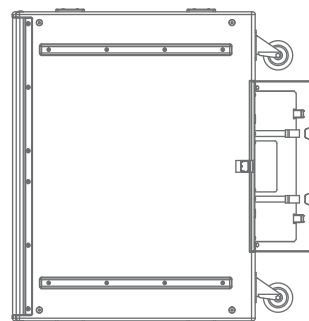

DSX-F

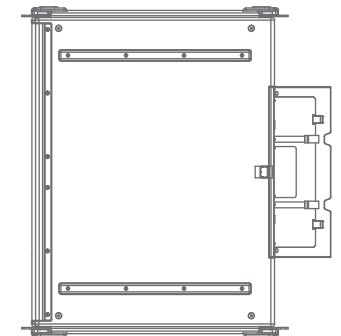

Note: Not to same scale as page 22

Martin Audio Limited

Century Point

Halifax Road

Cressex Business Park

High Wycombe

Buckinghamshire

HP12 3SL

England

FOR SALES ENQUIRIES:

UK

Telephone: +44 (0)1494 535312

E-mail: info@martin-audio.com

NORTH AMERICA

Telephone: 818 649 7776

[818 649 7776](tel:8186497776)



All information is Copyright © 2012 Martin Audio Ltd.

Martin Audio, the Martin Audio logo and Hybrid are registered trademarks of Martin Audio Ltd. in the United Kingdom, United States and other countries; all other Martin trademarks are the property of Martin Audio Ltd.

www.martin-audio.com