



ULTRA-COMPACT MULTI-CELLULAR LOUDSPEAKER ARRAY





With the introduction of the award-winning MLA® and MLA Compact™ systems, Martin Audio turned the line array world on its head. Different in concept to line array, MLA's combination of individually driven cells and automated numerical optimisation delivers much more consistent sound across the audience, puts an end to trial-and-error tuning sessions and reduces sound spill – both on stage and beyond the audience boundary.

Now, the ultra-compact MLA Mini™ brings revolutionary MLA cellular technology to an exceptionally wide range of smaller-scale portable and installed sound applications. Its very small footprint and light weight makes it the system of choice for smaller venues which require the ultimate in fidelity, consistency and control.



MLA CELLULAR TECHNOLOGY BEYOND LINE ARRAY

With conventional line arrays, the aim is to produce coherent wavefronts as they exit the speaker grilles – with the user having limited control over what actually arrives on the audience floor.

MLA cellular technology takes the reverse approach. The user specifies exactly what SPL and frequency response is required at various points throughout the venue and intelligent software automatically determines the array configuration and controls each individual cell in the array to produce that result. With independent control of every cell in the array, MLA systems are not constrained by the 3dB decrease in SPL with doubling of distance associated with conventional line arrays. Instead, the frequency response and SPL's at the rear seats closely track the front rows.

With every cell under software control, 'Hard-avoid' areas, such as onstage, the ceiling and the venue perimeter can also be programmed in to reduce sound spill, and vertical coverage can be fine-tuned electronically in-situ without the need to re-rig the array.

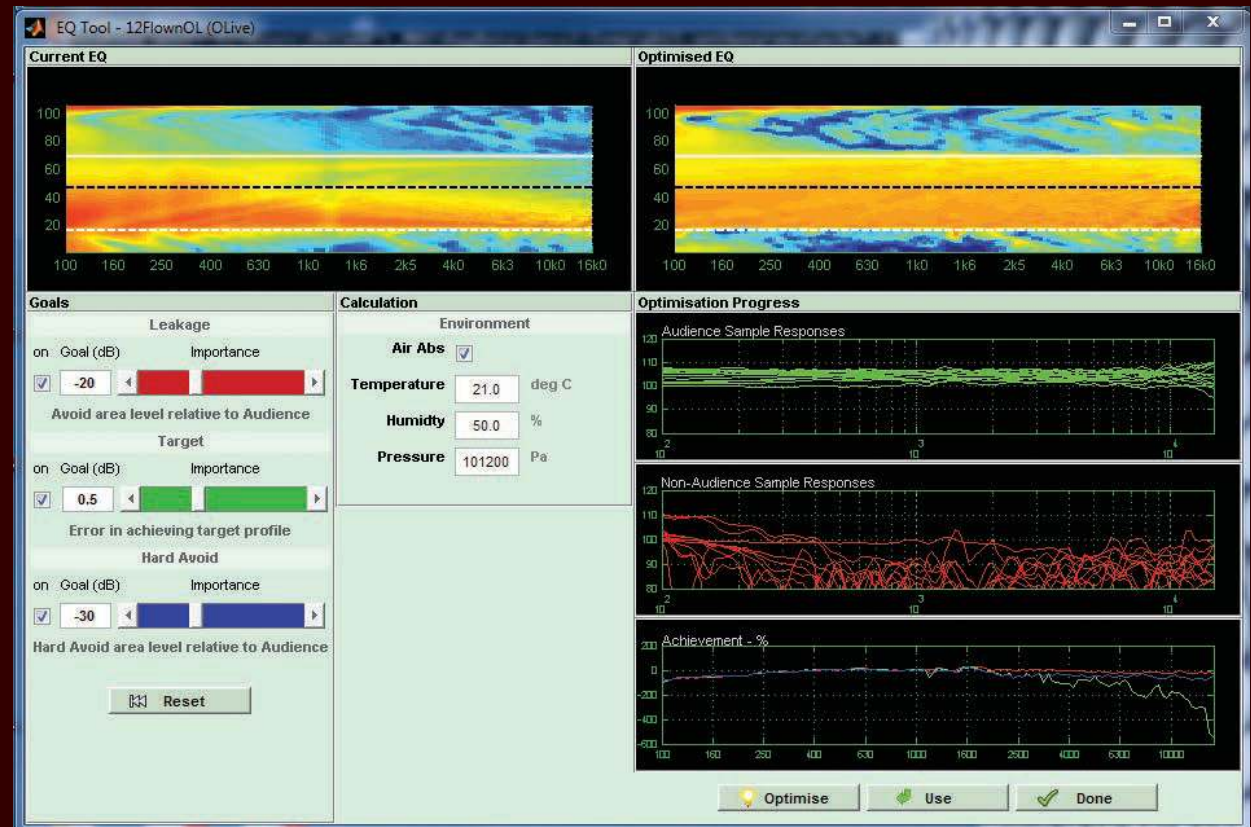

▲ Automated optimisation

MLA MINI ULTRA-COMPACT VERSATILITY

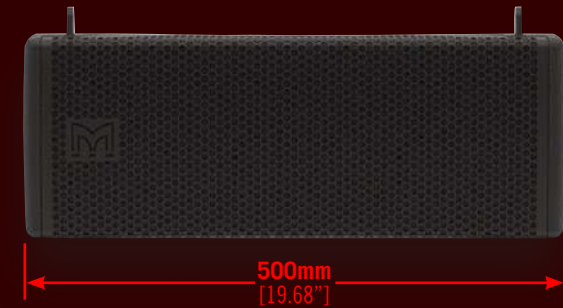

Scalable and versatile, MLA Mini is ideal for portable sound rental, small-to-medium ballroom, theatre and HoW applications and is the natural choice as an infill for MLA Compact systems. Its ultra-compact size understates its output capabilities – a 12-box array will throw beyond 35 metres (115ft) and deliver live music in venues of 750-1000 people.

MLA Mini is designed as a complete system, with a companion MSX mini-sub power plant which houses the amplification and DSP to power and control itself and up to 4 MLA Mini enclosures. Up to 16 MLA Minis can be flown in an array and powered by 4 ground-stacked MSX's. Alternatively, 12 MLA Minis can be flown below 3 MSX's in the same array. Since MLA Mini is a 2-way system, a 12-box array has a total of 12 HF cells and 12 LF cells, each individually powered to provide consistent coverage.

Arrays and MSX's can be remotely controlled from a laptop or wireless tablet running VU-NET™ control software with its intuitive graphical interface. In the simplest configuration, 4 MLA Minis can be pole-mounted above the MSX as a plug-and-play system using onboard presets instead of computer control.



**MLA Mini is
designed as a
complete system**



MLA MINI FEATURES AND BENEFITS

FEATURES

- Numerically optimised, ultra-compact loudspeaker system
- Cellular array format with amplification, multi-cellular DSP and digital networking housed in companion sub-bass
- Dedicated Class D amplifiers for individual powering of individual cells
- Industry leading DISPLAY 2.1™ intelligent software interacts with DSP for highly accurate array optimisation
- Vertical coverage can be fine-tuned electronically to cope with changing environmental conditions and last minute changes in rigging height. "Hard-avoid" areas, such as on-stage, ceilings and site perimeter, can be programmed in
- Switched mode power supplies with PFC (Power Factor Correction) and global mains voltage operation
- Two-way design delivers LF/HF peak SPL's of 130/132dB @ 1m from a single, ultra-compact enclosure
- Fast, integral flying system for suspension of up to 16 MLA Mini or 12 MLA Mini + 3 MSX enclosures
- True 100° (-6dB) horizontal constant directivity. Consistent and usable out to 125° (-10dB)
- 76Hz-18kHz ± 3dB frequency response

BENEFITS

- Automatic, intelligent configuration and numerical optimisation eliminates trial-and-error tuning sessions
- Desired house-curve and precise audience coverage achieved 'straight out of the box'
- Artistic changes to balance at the mix position (or elsewhere) translate directly and accurately throughout the audience
- "Greener", more efficient audio power via PFC (Power Factor Correction)
- Programmable leakage parameter to reduce sound spill

APPLICATIONS

- Small-to-medium scale theatres
- Small-to-medium live music venues
- Corporate AV events
- Fixed installations in concert halls, ballrooms and HoW
- Side-fill for MLA Compact systems



MLA MINI INNOVATIVE ACOUSTIC DESIGN

Each LF diaphragm follows the contours of the horn wall

Each MLA Mini enclosure houses 2 x 6.5" (165mm)/2" (50mm) voice coil LF drivers and a vertical column of 3 x 1.4" (35mm) aluminium dome HF drivers on a 100° horizontal dispersion horn. The LF drivers are located in the side walls of the horn. In a system using conventional cone drivers, this arrangement would introduce cavities into the horn walls which would degrade the horizontal dispersion characteristics. MLA Mini adopts an ingenious solution – each LF driver has a solid moulded diaphragm and low-diffraction surround which closely follows the contours of the horn wall.

Each LF driver also features a demodulation ring in the neodymium motor system to minimise distortion and maximise mid-band sensitivity, and the entire magnet structure is retained within the aluminum chassis for good thermal conduction.

In the triple-HF section, the voice coil of each HF driver is thermally coupled to its neodymium motor assembly and aluminium heatsink. An elastomer surround and low compression ratio combine to achieve low distortion, and a copper pole sleeve maximises HF efficiency. Each individual HF wavefront is precisely coupled to the horn throat via a short waveguide, for exemplary 100° horizontal constant-directivity coverage.

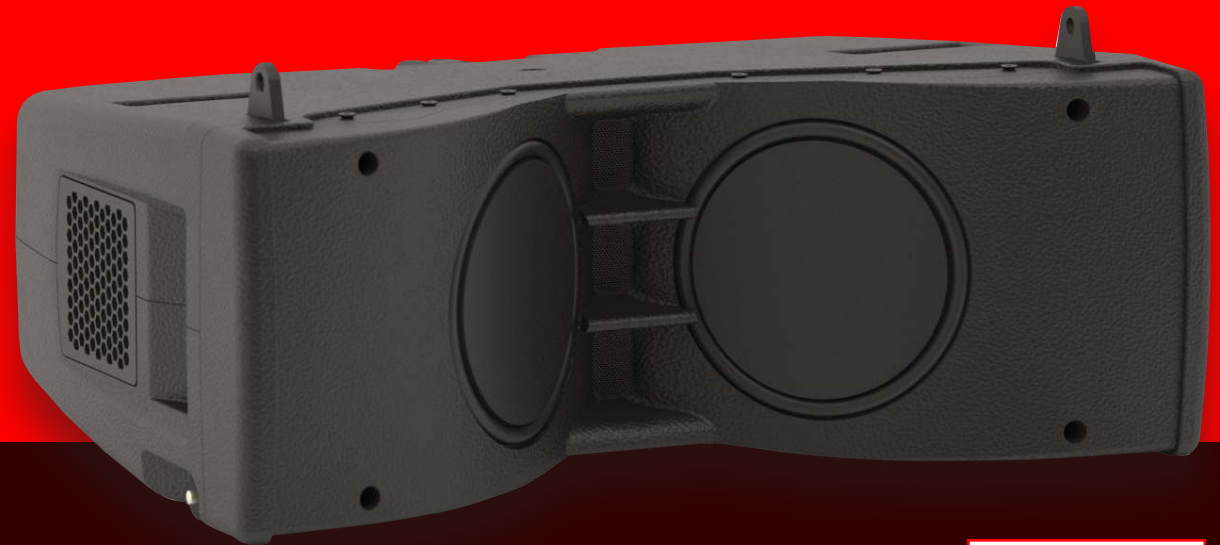

HF driver section ►



MLA MINI MSX MINI-SUB POWER PLANT



Amplification, networking and DSP are all housed in MLA Mini's companion MSX power plant, which includes 9 channels of Class D amplification – 1 channel for itself, and 8 channels to provide cellular drive of up to 4 bi-amped MLA Mini enclosures. Crossover, delay and EQ functions are implemented by a combination of IIR and FIR filters.

MLA Mini arrays and MSX's can be remotely controlled over the U-NET™ network from a laptop or wireless tablet running VU-NET control software. Small-scale systems – such as the configuration of 4 x MLA Minis and 1 x MSX – can be set up to plug-and-play without external control, with onboard presets recalled by a rear panel selector switch.

The MSX is the same width as the MLA Mini and can be integrated into flown arrays or ground-stacked separately. It features a 15" (380mm)/4" (100mm) voice coil, long-excursion driver reflex-loaded in a very compact enclosure.

For complete installation versatility, the power plant module itself can be rack-mounted and its sub-bass amplifier channel used to power either an MSX or an alternative Martin Audio 4 Ohm passive subwoofer. For ultimate sub-bass performance, the MLA Mini/MSX combination can be used with the powered DSX subwoofer.



DISPLAY 2.1 AUTOMATED CONTROL SOFTWARE

Deliver consistent sound throughout the venue

DISPLAY 2.1 is the brain of MLA Mini. Based on a highly accurate acoustic model of array behaviour, it gives a very accurate prediction of the direct sound produced over the audience as well as areas where sound is to be reduced. Its numerical optimisation process eliminates lengthy trial-and-error tuning sessions – an MLA Mini system achieves the required audience coverage straight out of the box.

DISPLAY 2.1 works from an audience perspective. Starting with a user-specified SPL and response over the audience floor, it automatically determines the array configuration that will give the required result. It takes the guesswork out of array design and deployment – generating highly accurate spot frequency responses and comprehensive rigging information, including mechanical load safety analysis. The software interacts with onboard DSP in the MSX to deliver consistent sound throughout the venue. It calculates the filter parameters for the LF and HF cells within each MLA Mini enclosure and uploads them via the U-NET digital network.

It can also fine-tune the vertical coverage after rigging without the need to reposition the array or change the inter-cabinet splay angles.

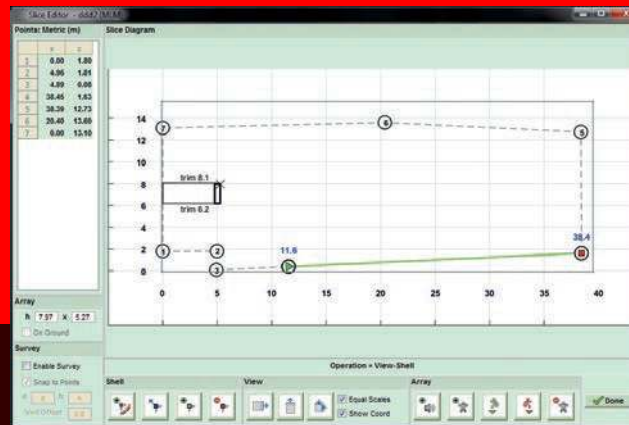

▲ Step 1: Venue entry

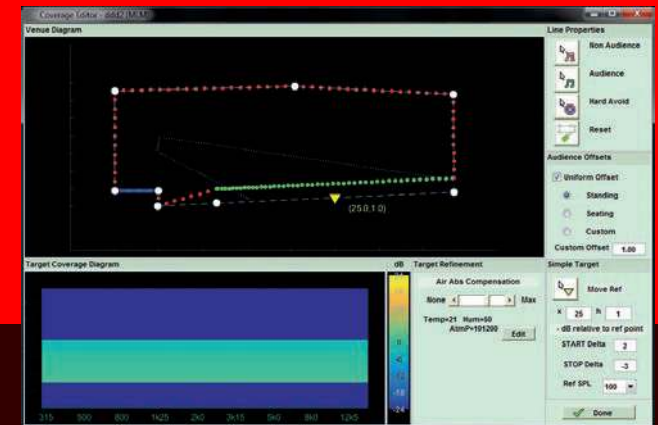

▲ Step 2: Set coverage parameters

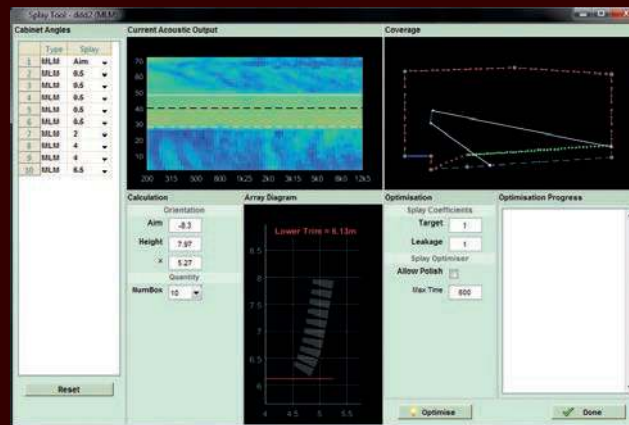

▲ Step 3: Calculate splay angles



▲ Step 4: Optimisation and upload

MLA MINI FLEXIBLE CONFIGURATIONS

MLA Mini is portable, easy to rig and fulfils a wide variety of applications. Its integral rigging system combines speed with precision. Up to 16 MLA Mini enclosures or 12 MLA Minis + 3 MSX's can be suspended via the single/two-point-lift flying frame – with a separate transition frame used to fly the MLA Minis beneath the MSX's. The flying frame can also be used to ground stack up to 6 MLA Mini enclosures.

Inter-cabinet connections utilise quick-release pins, with all loads being borne by the integral metalwork. DISPLAY 2.1 determines the safe limits and tilt angles of a specific array – including BGV C1 safety calculations. For small venues and infill applications, up to 4 MLA Minis can be pole-mounted above an MSX and aimed by means of an optional bracket assembly with precisely adjustable tilt angle. The same bracket can also be used to suspend 4 MLA Minis from a truss.

An optional flight case enables 4 MLA Mini enclosures to be transported face-down and the rear splay angles set whilst in the flight case prior to lifting. The MSX has a removable wheelboard option, and a protective transit cover is also available.



MLA MINI

SPECIFICATIONS AND DIMENSIONS

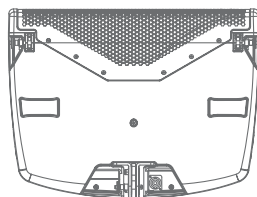
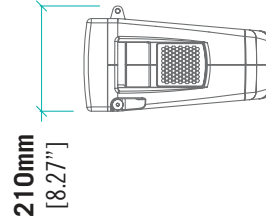
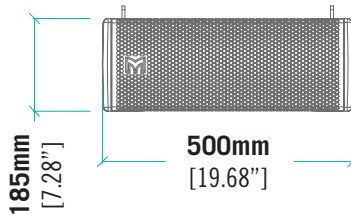
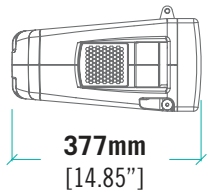
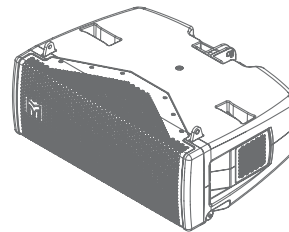
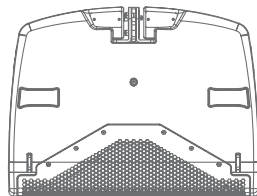
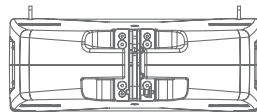

Acoustical	
TYPE	Two-way cellular-drive, array element, driven from MSX mini-subwoofer power plant
FREQUENCY RESPONSE (1)	76Hz-18kHz \pm 3dB -10dB @ 63Hz
MAXIMUM SPL @ 1m	
1 x MLA Mini	LF: 127dB continuous, 130dB peak (3) HF: 122dB continuous, 132dB peak (3)
4 x MLA Mini	LF: 139dB continuous, 142dB peak (3) HF: 132dB continuous, 142dB peak (3)
Drivers	
LF	2 x 6.5" (165mm) contoured-diaphragm/2" (50mm) edge-wound CCAW voice coil, neodymium magnet drivers, reflex loaded
HF	3 x 1.4" (35mm) aluminium dome/1.4" (35mm) voice coil, neodymium magnet compression drivers on constant-directivity waveguide
Rated Power (2)	
LF	300W AES, 1200W peak
HF	90W AES, 360W peak
Dispersion	
(-6dB)	100° horizontal
(-10dB)	125° horizontal 10° vertical
Crossover Frequency	
1.2kHz	Vanishing Point™ FIR filter
Audio input CONNECTORS	
	NL4 input, connects to MSX power plant LF 1+, 1-, HF 2+, 2-
General	
ENCLOSURE	Vertical trapezoid with 5° wall angle. Skeletal steel braced, ribbed ABS structural foam construction
FINISH	Textured black paint
PROTECTIVE GRILLE	Black HEX perforated steel, Declon™ backed
FITTINGS	Integral flyware for suspension of up to 16 MLA Mini Ergonomic handles on each side
IP RATING	IP 25
DIMENSIONS	(W) 500mm x (H) 210mm x (D) 377mm (including flyware) (W) 19.7in x (H) 8.3in x (D) 14.8in (including flyware)
WEIGHT	13.8kg (30.4lbs)

Notes
 (1) Measured on-axis on ground plane (2 π space) at 2 metres, then referred to 1 metre.
 (2) AES Standard ANSI S4.26-1984.
 (3) Calculated in half-space at 1 metre.

MSX

SPECIFICATIONS AND DIMENSIONS

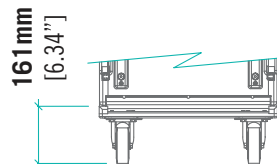
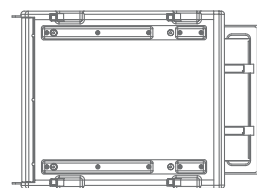
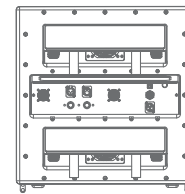
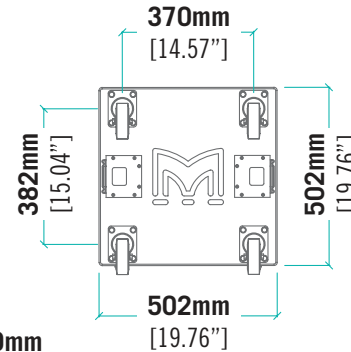
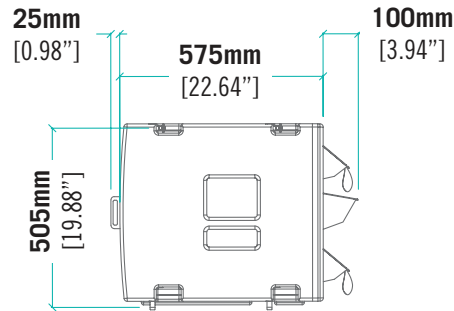
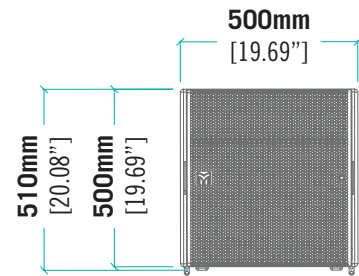

System Accessories

- Flight case for 4 x MLA Mini
- Universal tilt bracket
- Variable height pole mount
- MSX transit cover with integral plywood lid
- Wheelboard with 4 x 100mm castors
- Flying frame, including clinometer
- Transition frame for suspending MLA Mini beneath

MSX

- Flying pin
- Ground stack bars
- Ground stack base plate
- Mains distribution system
- Tour-grade network interconnects
- Merlin Controller/U-NET Hub

Acoustical

TYPE	15" reflex loaded subwoofer
FREQUENCY RESPONSE (1)	50Hz-150Hz ± 3dB
	-10dB @ 42Hz
MAXIMUM SPL @ 1m	133dB continuous, 136dB peak (3)
Driver	1 x 15" (380mm)/4" (100mm) voice coil, ultra-long excursion, high efficiency ferrite magnet
Rated Power (2)	800W AES, 3200W peak

MSX Dispersion

Omnidirectional. Cardioid arrays possible, using multiple MSX enclosures

Audio input

CONNECTORS	Female XLR input, male XLR link output
ANALOGUE INPUT IMPEDANCE	20kΩ balanced to ground
MAXIMUM ANALOGUE INPUT LEVEL	6.15Vrms (+18dBu), over voltage protected
AES/EBU IMPEDANCE	110 Ohms balanced, receive and transmit termination

Internal Processing

	Multi-channel DSP, programmable via network
	10 PEQ/shelving filters per channel
	Up to 48dB/Oct HPF and LPF
	FIR filtering on MLA Mini channels
	Up to 1 second of delay
	Limiters with amplifier output current monitoring

Network

CONNECTORS	IP68 rated 8-way, quick-release type
PROTOCOL	U-NET

Amplifier Module

TYPE	9 channel switch-mode, class D
PEAK OUTPUT POWER	7000W total
	1400W MSX (or alternative 4 Ohm subwoofer)
	700W MLA Mini LF x 4
	700W MLA Mini HF x 4

CONNECTORS	2 x NL8 outputs to MLA Mini x 4
------------	---------------------------------

AVERAGE EFFICIENCY	85%
--------------------	-----

COOLING	2 x temperature controlled internal fans
	1 x low-speed internal blower
	2 x temperature controlled external fans

MAXIMUM AMBIENT TEMPERATURE	45°C (113°F) for full output
-----------------------------	------------------------------

Power Supply

TYPE	Switch mode, fixed frequency with PFC
AC INPUT OPERATING RANGE	100 – 240V ~ AC, 50 – 60Hz

POWER FACTOR	> 0.95
--------------	--------

NOMINAL POWER CONSUMPTION	900W
---------------------------	------

MAINS CONNECTOR	Neutrik® Powercon True1
-----------------	-------------------------

General

ENCLOSURE	Extensively braced multi-laminate birch-ply
FINISH	Textured black PU coating
PROTECTIVE GRILLE	Black HEX perforated steel

FITTINGS

Two skids on base, with mating channels on top
M20 top-mounted thread plate for MLA Mini pole
Integral flyware for suspension of up to 4 MSX
Large bar handle on each side
Two front-mounted latch plates for wheelboard
Optional weather protection cowl

IP RATING

Indoor (without weather protection cowl)
IP 25 (with weather protection cowl)

DIMENSIONS

(W) 500mm x (H) 510mm x (D) 575mm (675mm with vent flap open)
(W) 19.7in x (H) 20.1in x (D) 22.6in (26.6in)

WEIGHT

58kg (128lbs)
65kg (143lbs) inc wheelboard

Notes

- (1) Measured on-axis on ground plane (2m space) at 2 metres, then referred to 1 metre.
- (2) AES Standard ANSI S4.26-1984.
- (3) Calculated in half-space at 1 metre.

Martin Audio Limited

Century Point

Halifax Road

Cressex Business Park

High Wycombe

Buckinghamshire

HP12 3SL

England

FOR SALES ENQUIRIES:

UK

Telephone: +44 (0)1494 535312

E-mail: info@martin-audio.com

NORTH AMERICA

Telephone: 818 649 7776

All information is Copyright © 2017 Martin Audio Ltd.

Martin Audio, the Martin Audio logo and Hybrid are registered trademarks of Martin Audio Ltd. in the United Kingdom, United States and other countries; all other Martin Audio trademarks are the property of Martin Audio Ltd.

www.martin-audio.com
www.martinaudio-mla.com

Version 2.1