



MLA Mini

Multi-Cellular Loudspeaker Array

Features

- Numerically optimised, ultra-compact loudspeaker system
- Cellular array format with amplification, multi-cellular DSP and digital networking housed in companion sub-bass
- Dedicated Class D amplifiers for individual powering of individual cells
- Industry leading DISPLAY2.1™ intelligent software interacts with DSP for highly accurate array optimisation
- Vertical coverage can be fine-tuned electronically to cope with changing environmental conditions and last minute changes in rigging height
- “Hard-avoid” areas, such as on-stage, ceilings and site perimeter, can be programmed in
- Switched mode power supplies with PFC (Power Factor Correction) and global mains voltage operation
- Two-way design delivers LF/HF peak SPL's of 130/129dB @ 1m from a single, ultra-compact enclosure
- Fast, integral flying system for suspension of up to 16 MLA Mini or 12 MLA Mini + 3 MSX enclosures
- True 100° (-6dB) horizontal constant directivity. Consistent and usable out to 125° (-10dB)
- 76Hz-18kHz ± 3dB frequency response

Benefits

- Automatic, intelligent configuration and numerical optimisation eliminates trial-and-error tuning sessions
- Desired house-curve and precise audience coverage achieved ‘straight out of the box’
- Artistic changes to balance at the mix position (or elsewhere) translate directly and accurately throughout the audience
- “Greener”, more efficient audio power via PFC (Power Factor Correction)
- Programmable leakage parameter to reduce sound spill

Applications

- Small-to-medium scale theatres
- Small-to-medium live music venues
- Corporate AV events
- Fixed installations in concert halls, ballrooms and HoW
- Side-fill for MLA Compact systems



Martin Audio's revolutionary award-winning Multi-cellular Loudspeaker Array [MLA] technology is reinventing the way loudspeaker arrays are configured and controlled — combining unsurpassed audience coverage and consistency with superior fidelity.

The ultra-compact MLA Mini brings this revolutionary technology to an exceptionally wide range of portable sound and showcase events, as well as fixed installations ranging from theatres and ballrooms to Houses of Worship and concert halls.

With multiple awards for innovation, MLA Mini's small footprint and light weight makes it the system of choice for small-medium scale venues seeking the ultimate in fidelity, consistency and control.

In its simplest terms a 16-enclosure MLA Mini array has 32 individual acoustic elements [cells], each with its own amplifier and DSP, which can be optimised by software to deliver the sound across the audience to meet the sonic goals required for any space.

MLA technology is the only technology on the market to allow multiple sonic goals to be prioritised and optimised accordingly. For example, not only can MLA Mini generate an even sound field over the audience, it can contain it as well — significantly reducing the influence of the room.

‘Hard avoid’ areas - such as behind and below the array, ceilings, balcony edges and beyond the venue perimeter - can also be programmed in. Vertical coverage can even be fine-tuned electronically in-situ to cope with changing environmental conditions and last-minute changes in rigging height, without having to re-rig.

With incredibly easy-to-use and highly accurate predictive software [DISPLAY] doing all the grunt work with the system, the engineer retains full artistic control and can enjoy mixing the show in the full knowledge that the sound created at the mix position will be heard everywhere throughout the audience.

Amplification, networking and DSP are all housed in MLA Mini's companion MSX power-plant, which includes 9 channels of Class D amplification – 1 channel for itself, and 8 channels to provide multi-cellular drive of up to 4 bi-amped MLA Mini enclosures. Crossover, delay and EQ functions are implemented by a combination of IIR and FIR filters.

Such is the confidence that MLA Mini can bring, that significantly less time is spent setting up the system and less time is spent walking the room to verify results.

MLA Mini

Multi-Cellular Loudspeaker Array

Technical Drawing

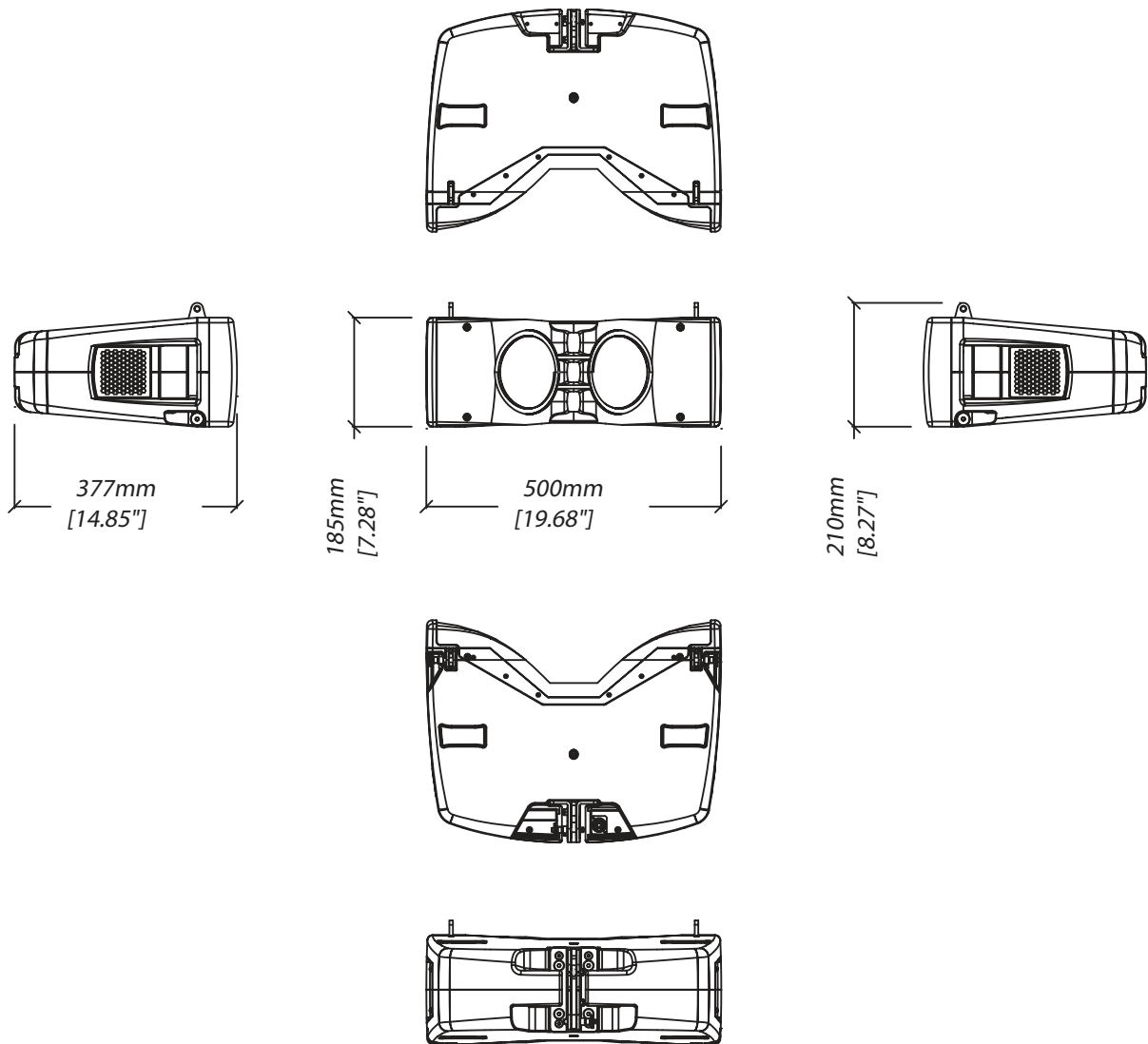



MLA Mini

Multi-Cellular Loudspeaker Array

Technical Specifications

Acoustical	
TYPE	Two-way cellular-drive, array element, driven from MSX mini-subwoofer power plant
FREQUENCY RESPONSE (1)	76Hz-18kHz \pm 3dB -10dB @ 63Hz
MAXIMUM SPL @ 1m	
1 x MLA Mini	LF: 127dB continuous, 130dB peak (3) HF: 122dB continuous, 132dB peak (3)
4 x MLA Mini	LF: 139dB continuous, 142dB peak (3) HF: 132dB continuous, 142dB peak (3)
Drivers	
LF	2 x 6.5" (165mm) contoured-diaphragm/2" (50mm) edge-wound CCAW voice coil, neodymium magnet drivers, reflex loaded
HF	3 x 1.4" (35mm) aluminium dome/1.4" (35mm) voice coil, neodymium magnet compression drivers on constant-directivity waveguide
Rated Power (2)	
LF	300W AES, 1200W peak
HF	90W AES, 360W peak
Dispersion	
(-6dB)	100° horizontal
(-10dB)	125° horizontal 10° vertical
Crossover Frequency	
1.2kHz	Vanishing Point™ FIR filter
Audio input	
CONNECTORS	NL4 input, connects to MSX power plant LF 1+, 1-, HF 2+, 2-
General	
ENCLOSURE	Vertical trapezoid with 5° wall angle. Skeletal steel braced, ribbed ABS structural foam construction
FINISH	Textured black paint
PROTECTIVE GRILLE	Black HEX perforated steel, Declon™ backed
FITTINGS	Integral flyware for suspension of up to 16 MLA Mini Ergonomic handles on each side
IP RATING	IP 25
DIMENSIONS	
	(W) 500mm x (H) 210mm x (D) 377mm (including flyware) (W) 19.7in x (H) 8.3in x (D) 14.8in (including flyware)
WEIGHT	13.8kg (30.4lbs)

Accessories

- Flight case for 4 x MLA Mini
- Universal tilt bracket
- Variable height pole mount
- MSX transit cover with integral plywood lid
- Wheelboard with 4 x 100mm castors
- Flying frame, including clinometer
- Transition frame for suspending MLA Mini beneath

Notes

- (1) Measured on-axis on ground plane (2 π space) at 2 metres, then referred to 1 metre.
- (2) AES Standard ANSI S4.26-1984.
- (3) Calculated in half-space at 1 metre.

Trade Descriptions Act

Due to Martin Audio's policy of continuing improvement, we reserve the right to alter these specifications without prior notice. Martin Audio is committed to refining state of the art sound reinforcement, combining in-depth product and field applications research with advanced manufacturing techniques. Every Martin Audio product is built to the highest manufacturing standards and rigorously tested to ensure that it meets the performance criteria specified in the design.

MSX

15" Subwoofer for MLA Mini

Technical Specifications

Acoustical

TYPE	15" reflex loaded subwoofer
FREQUENCY RESPONSE (1)	50Hz-150Hz ± 3dB -10dB @ 42Hz
MAXIMUM SPL @ 1m	133dB continuous, 136dB peak (3)

Driver

1 x 15" (380mm)/4" (100mm) voice coil, ultra-long excursion, high efficiency ferrite magnet

Rated Power (2)

800W AES, 3200W peak

MSX Dispersion

Omnidirectional. Cardioid arrays possible, using multiple MSX enclosures

Audio input

CONNECTORS	Female XLR input, male XLR link output
ANALOGUE INPUT IMPEDANCE	20kΩ balanced to ground
MAXIMUM ANALOGUE INPUT LEVEL	6.15Vrms (+18dBu), over voltage protected
AES/EBU IMPEDANCE	110 Ohms balanced, receive and transmit termination
Internal Processing	Multi-channel DSP, programmable via network 10 PEQ/shelving filters per channel Up to 48dB/Oct HPF and LPF FIR filtering on MLA Mini channels Up to 1 second of delay Limiters with amplifier output current monitoring

Network

CONNECTORS	IP68 rated 8-way, quick-release type
PROTOCOL	U-NET

Amplifier Module

TYPE	9 channel switch-mode, class D
PEAK OUTPUT POWER	7000W total 1400W MSX (or alternative 4 Ohm subwoofer) 700W MLA Mini LF x 4 700W MLA Mini HF x 4
CONNECTORS	2 x NL8 outputs to MLA Mini x 4
AVERAGE EFFICIENCY	85%
COOLING	2 x temperature controlled internal fans 1 x low-speed internal blower 2 x temperature controlled external fans
MAXIMUM AMBIENT TEMPERATURE	45°C (113°F) for full output

Power Supply

TYPE	Switch mode, fixed frequency with PFC
AC INPUT OPERATING RANGE	100 – 240V ~ AC, 50 – 60Hz
POWER FACTOR	> 0.95
NOMINAL POWER CONSUMPTION	900W
MAINS CONNECTOR	Neutrik® Powercon True1

General

ENCLOSURE	Extensively braced multi-laminate birch-ply
FINISH	Textured black PU coating
PROTECTIVE GRILLE	Black HEX perforated steel

FITTINGS	Two skids on base, with mating channels on top M20 top-mounted thread plate for MLA Mini pole Integral flyware for suspension of up to 4 MSX Large bar handle on each side Two front-mounted latch plates for wheelboard
IP RATING	Indoor (without weather protection cowl) IP 25 (with weather protection cowl)

DIMENSIONS	(W) 500mm x (H) 510mm x (D) 575mm (675mm with vent flap open) (W) 19.7in x (H) 20.1in x (D) 22.6in (26.6in)
------------	--

WEIGHT	58kg (128lbs) 65kg (143lbs) inc wheelboard
--------	---

ACCESSORIES	Flying pin Ground stack bars Ground stack base plate Mains distribution system Tour-grade network interconnects Merlin Controller/U-NET Hub
-------------	--

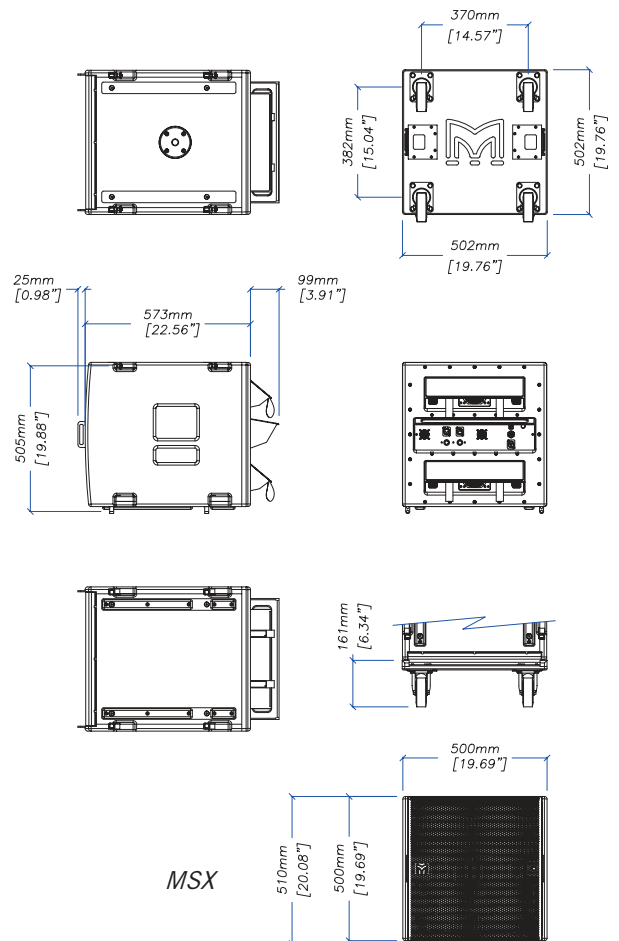

Notes

- (1) Measured on-axis on ground plane (2p space) at 2 metres, then referred to 1 metre.
- (2) AES Standard ANSI S4.26-1984.
- (3) Measured in half-space at 1 metre with a tone burst signal.