

# T1215

## Passive, 15° Fixed Angle Array Cabinet



### Features

- 1 x 12" (300mm) LF driver & 3 x 1.4" (35mm) HF drivers
- Passive fixed angle array cabinet of 15° for a narrow vertical dispersion pattern
- Manually adjustable Dynamic Horn Flare™ (between 60°, 90° or 75° Asymmetrical) for flexible horizontal pattern
- Phase plug for increased mid-band sensitivity
- Optimised coverage via DISPLAY 3 and powered by iKON amplifiers
- Plug-and-play system, quick set-up and easy rigging

### Applications

- Optimised for short to medium-throw live sound and installation applications
- Fills, distributed systems, and centre clusters



For applications that typically require a throw between 15-30m, a full-blown line array is not always practical, optimal or affordable. Conversely, a point source solution may not be sufficient in coverage and SPL. TORUS is a constant curvature array, designed to fill that gap perfectly, combining optimised coverage, SPL and cost efficiency.

T1215 offers a narrow vertical pattern of 15° with a flexible horizontal pattern that can be manually adjusted between 90°, 60° or 75° (Asymmetrical) via the Dynamic Horn Flare™.

T1215 features a 12" (300mm) LF driver and three 1.4" (35mm) HF drivers and includes two NL4 connectors with passive configuration using pins 1+ 1- or 2+ 2- selected via rear-mounted switch. The plywood cabinets are finished in hardwearing Warnex paint with well positioned handles for easy installation and deployment. The integrated rigging is suitable for install and touring applications and supports horizontal array configurations of up to 180° with a flying frame that can support up to 6 cabinets in vertical orientation. The cabinets also feature a fixing for an external pole-mount accessory,

increasing the flexibility to the max. In addition, T1215 can be supplemented by SX subwoofers and designed to fully integrate with the cardioid subwoofer, SXCF118, for flown and ground-stack configurations.

Powered by Martin Audio iKON amplifiers, which support VU-NET and Dante®, T1215 can be modelled in 3D and optimised using DISPLAY 3, allowing different box resolutions as well as automatically optimising filtering to deliver consistent and defined coverage.

Available as standard in black (T1215B) or white (T1215W).

# T1215

## Passive, 15° Fixed Angle Array Cabinet

# TORUS

### Technical Specifications

TYPE	Passive 2-way Constant Curvature 15° enclosure
FREQUENCY RESPONSE (with iKON settings)	± 3dB @ 65Hz, -10dB @ 50Hz
DRIVERS	LF: 12", 3" Voice Coil, Neodymium HF: 3 x 1" exit, 1.4" Voice Coil, HT Polymer dome neodymium compression driver
SENSITIVITY	(2.83V 1m free-field) 100dB
NOMINAL IMPEDANCE	8 ohms
RATED POWER	AES 400W, PEAK 1600W
MAXIMUM SPL (SYSTEM)	128dB continuous, 134 dB peak*
DISPERSION	60-75-90° horizontal, 15° vertical
PIN CONNECTIONS (INPUT)	1+/- or 2+/-
PIN CONNECTIONS (LINK)	1+/- and 2+/-
DIMENSIONS	(W) 650mm, (H) 369mm, (D) 452mm (W) 25.59ins, (H) 14.51ins, (D) 17.80ins
WEIGHT	31kg (68.34 lbs)

\*Martin Audio continues to specify a crest factor of 2 with 6dB between peak and continuous which best mirrors real-world performance. Simply add a further 6dB for comparison with manufacturers quoting a crest factor of 4 ie. 12dB between continuous and peak.

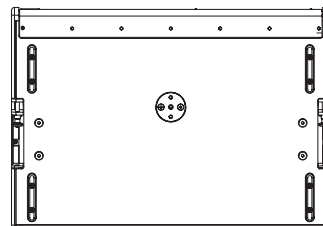
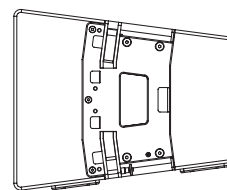
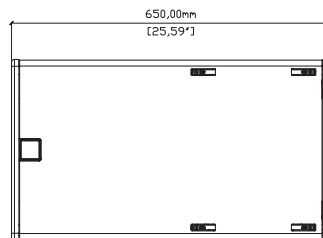
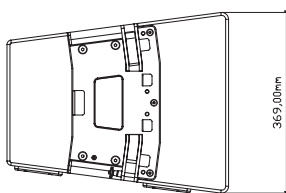
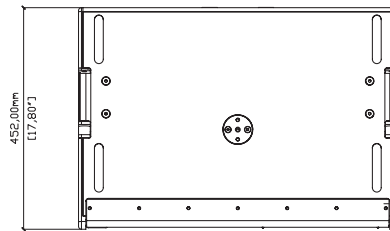
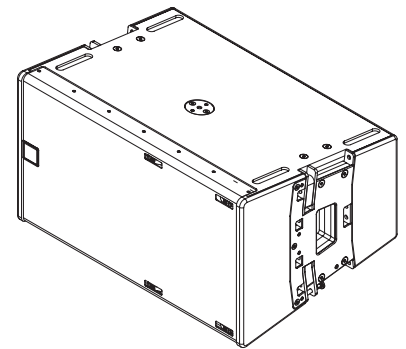

TORUS T1215