

# TORUS

THE DEFINITIVE CONSTANT CURVATURE



**Unite Your Audience**  
The Martin Audio Experience





# TORUS



For applications that typically require a throw between 15-30m, a full-blown line array is not always practical, optimal or affordable. Conversely, a point source solution may not be sufficient in coverage and SPL.

TORUS is a constant curvature array, designed to fill that gap perfectly, combining optimised coverage, SPL profile and cost efficiency.

However, it is much more than just another constant curvature array. TORUS was in development for three years in an exhaustive bid to further the acoustic concept and performance achievable.

Typically, constant curvature arrays have adjustable horizontal dispersion but their performance can vary considerably in terms of tonality and effectiveness of coverage when different dispersions are selected.

Equally, many lack sufficient sensitivity in the mid-band frequency, critically important for voice projection and clarity.

They also can suffer from comb filtering.

TORUS fundamentally addresses these areas and more.

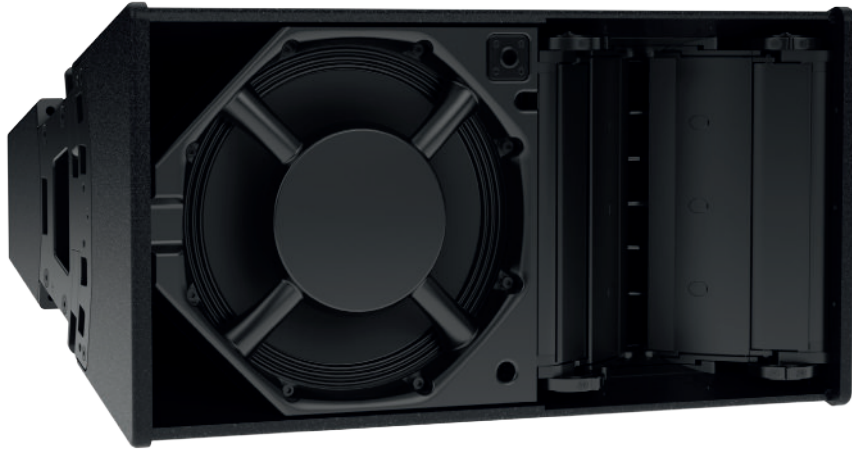

## FEATURES

- 1 x 12" (300mm) LF driver & 3 x 1.4" (35mm) HF drivers
- Two passive fixed angle array cabinets (15° or 30°) for vertical dispersion pattern flexibility
- Manually adjustable Dynamic Horn Flare™ (between 60°, 90° or 75° Asymmetrical) for flexible horizontal dispersion control
- Phase plug for increased mid-band sensitivity
- Optimised coverage via DISPLAY 3 and powered by iKON amplifiers
- Plug-and-play system, quick set-up and easy rigging

## APPLICATIONS

- Optimised for short to medium-throw live sound and installation applications
- Fills, distributed systems and centre clusters

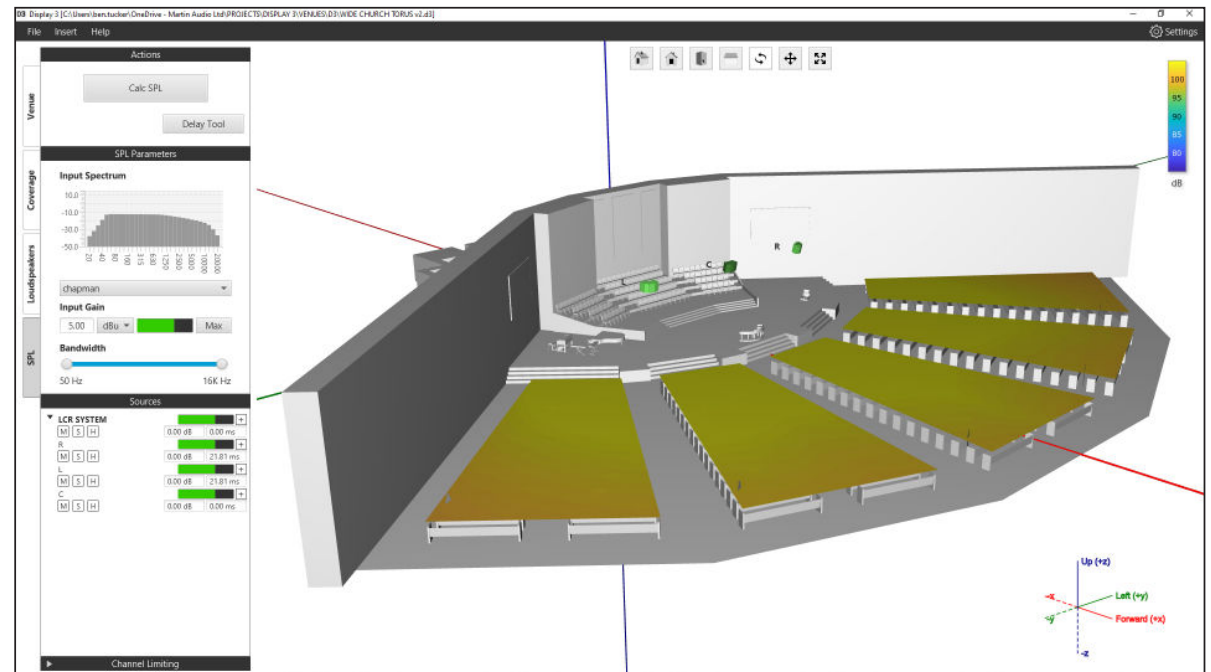



## DYNAMIC HORN FLARE™ - OPTIMAL HORIZONTAL PATTERN CONTROL

Each TORUS cabinet is designed for a flexible horizontal dispersion pattern and this can be manually adjusted between 90°, 60° or 75° (Asymmetrical) via the unique Dynamic Horn Flare™. This not only moves and locks the waveguide but also adjusts the horn mouth, including the low diffraction termination into the baffle, to ensure correct geometry and optimal performance in each of those settings.

The Dynamic Horn Flare™ is moved by a rotating mechanism accessible from the front grille so is easy and intuitive, while leaving the grille design to be both smart and fully protective of the drivers within.

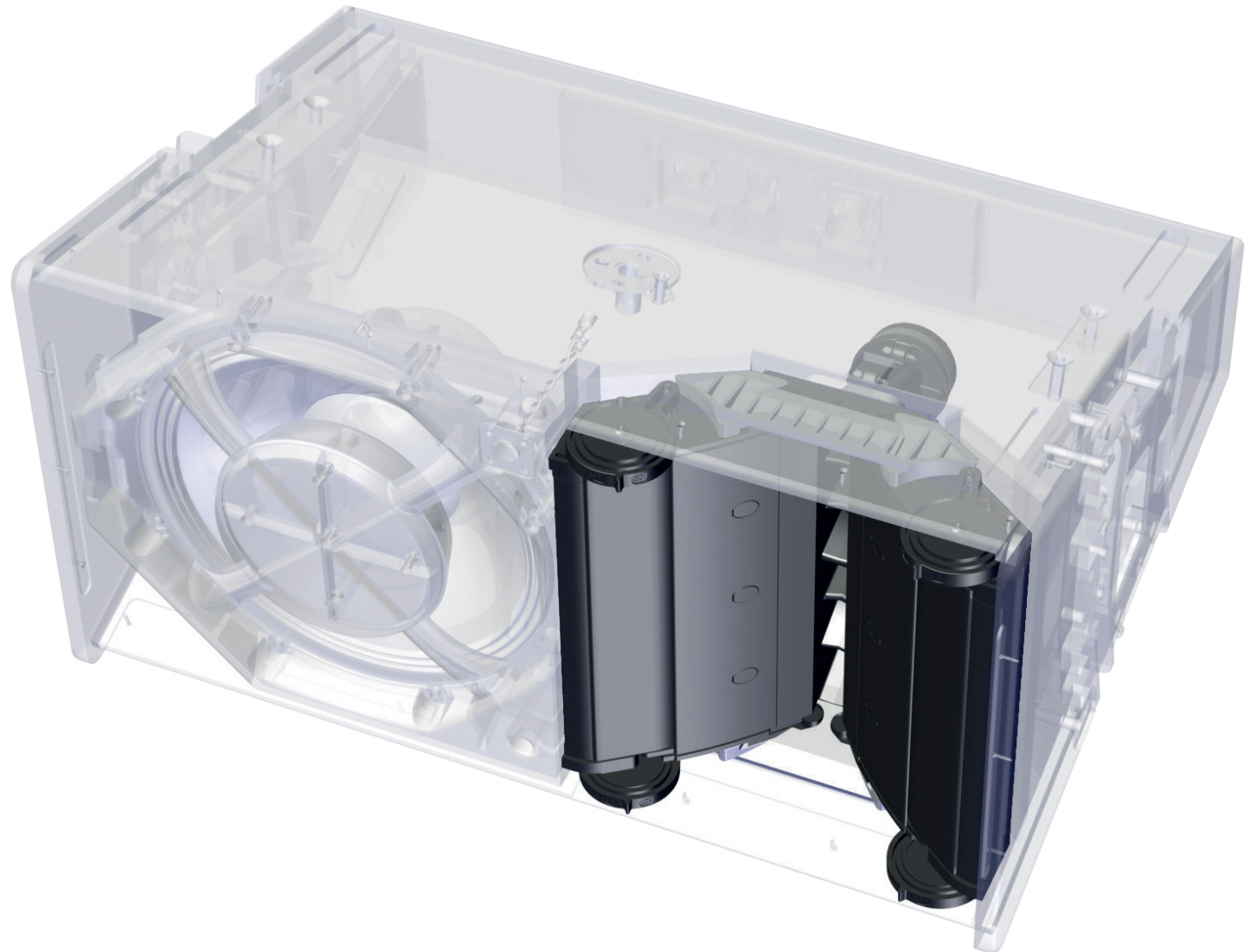

# TWO ANGLED CABINETS FOR OPTIMAL VERTICAL COVERAGE

A vertical pattern of either 15° or 30° is achieved via two separate cabinet types: T1215 and T1230, respectively. These cabinets can also be combined to fit venue and coverage requirements.



Combined Deployment



T1215



T1230



## INCREASED VOCAL PROJECTION AND CLARITY

TORUS features a phase plug mounted in front of the 12" neodymium driver to increase mid-band sensitivity. Along with three 1.4" HF Polymer dome neodymium compression drivers, the sonic performance is not compromised even when driven at higher SPL.

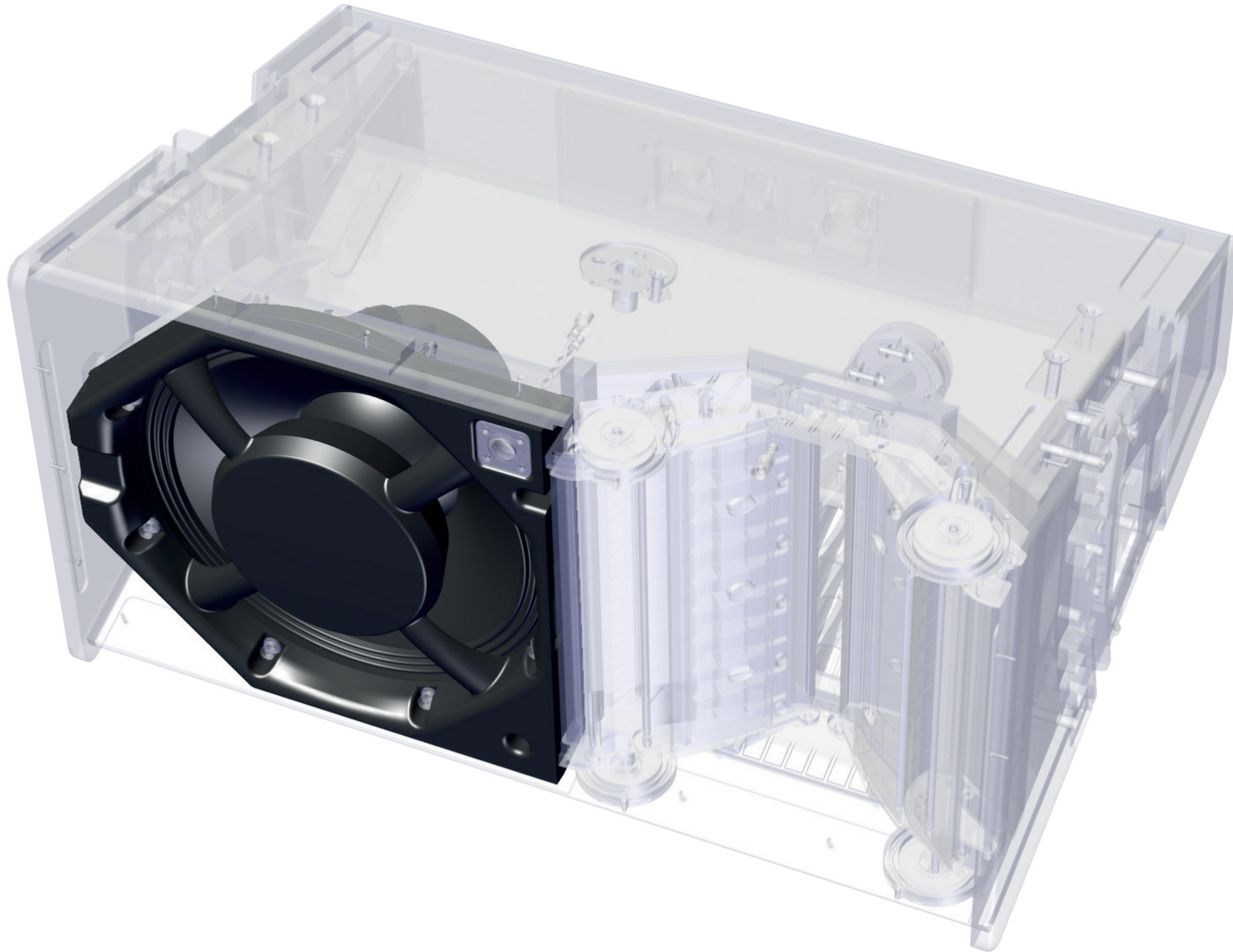



# DISPLAY 3 – 3D MODELLING AND OPTIMISATION

TORUS is the first product to take advantage of DISPLAY 3 and can therefore be modelled in 3D and optimised accordingly, allowing different box resolutions as well as automatically optimising filtering to deliver consistent and defined coverage.

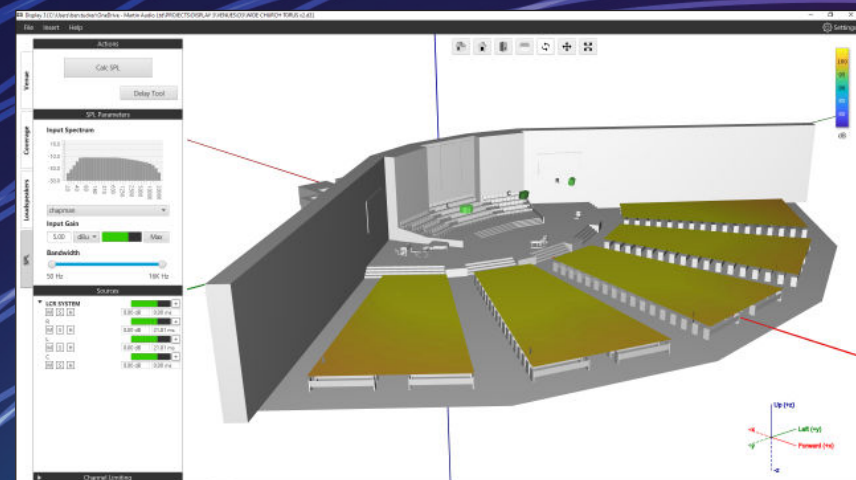
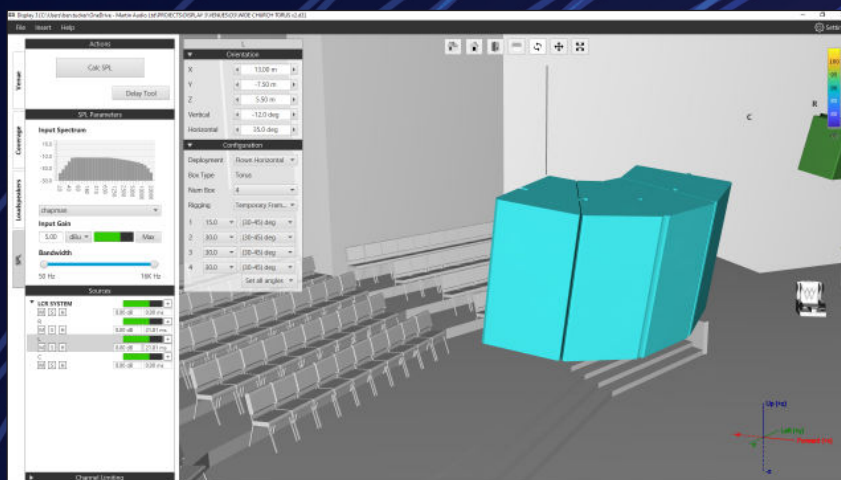
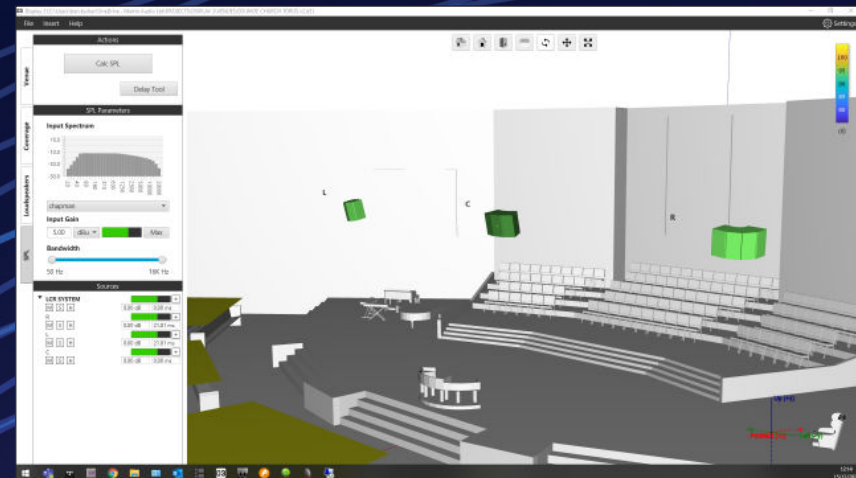
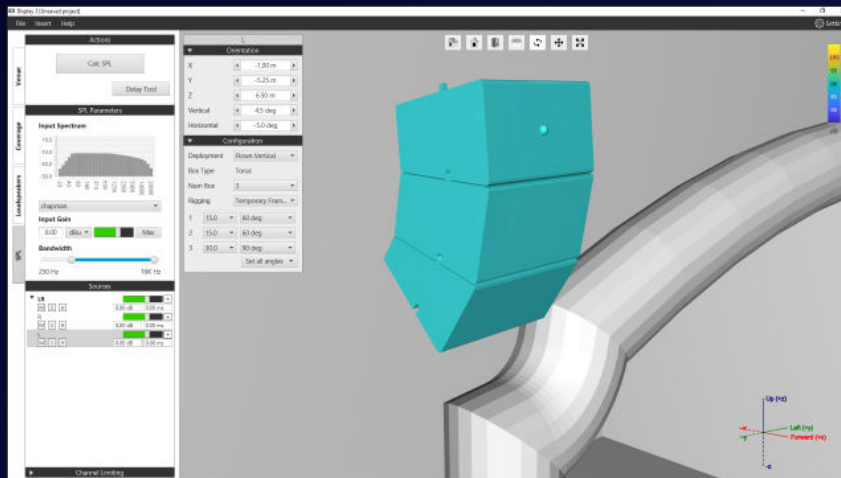

## PREMIUM CABINET DESIGN WITH FLEXIBLE DEPLOYMENT

The plywood cabinets are finished in hardwearing Warnex paint with well positioned handles for easy installation and deployment.

The integrated rigging is suitable for install and touring applications and support horizontal array configurations of up to 180° with a flying frame that can support up to 6 cabinets in vertical orientation. The cabinets also feature a fixing for an external pole-mount accessory, increasing the flexibility to the max.

All this and finished off with a fully fitting grille, leaving no exposed parts, enabling a premium yet discreet look.

TORUS is available as standard in black or white.



Pole Rig



SBAR



T12 GRID



T12 H-RIG



T12 T-RIG



T12-GS

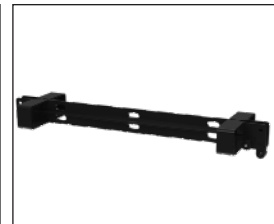

T12-PB



## AMPLIFICATION

Both models have two NL4 connectors with passive configuration using pins 1+ 1- or 2+ 2- selected via rear-mounted switch.

TORUS systems are powered by Martin Audio iKON amplifiers, which support VU-NET control software and Dante® integration.



iK42



iK81



## RECOMMENDED SUBWOOFER

TORUS can be supplemented by SX subwoofers and is specifically designed to fully integrate with the cardioid subwoofer, SXCF118, for flown and ground-stack configurations.

The SXCF118 is a compact, high performance cardioid subwoofer, combining maximum low frequency output with pattern control. It features an 18" (460mm) forward facing driver and a 14" (356mm) rear facing driver, each driven independently by separate amplifier channels and DSP. Each driver has its own chamber with optimised bass reflex porting. This arrangement produces a cardioid dispersion pattern which maximises the front radiation and reduces unwanted radiation behind the subwoofer.



SXCF118





# TECHNICAL SPECIFICATIONS

PRODUCT NAME	TORUS: T1215	TORUS: T1230
TYPE	Passive 2-way Constant Curvature 15° enclosure	Passive 2-way Constant Curvature 30° enclosure
FREQUENCY RESPONSE (with iKON settings)	± 3dB @ 65Hz, -10dB @ 50Hz	± 3dB @ 65Hz, -10dB @ 50Hz
DRIVERS	LF: 12", 3" Voice Coil, Neodymium HF: 3 x 1" exit, 1.4" Voice Coil, HT Polymer dome neodymium compression driver	LF: 12", 3" Voice Coil, Neodymium HF: 3 x 1" exit, 1.4" Voice Coil, HT Polymer dome neodymium compression driver
SENSITIVITY	(2.83V 1m free-field) 100dB	(2.83V 1m free-field) 99dB
NOMINAL IMPEDANCE	8 ohms	8 ohms
RATED POWER	AES 400W, PEAK 1600W	AES 400W, PEAK 1600W
MAXIMUM SPL (SYSTEM)	128dB continuous, 134 dB peak*	126dB continuous, 132dB peak*
DISPERSION	60-75-90° horizontal, 15° vertical	60-75-90° horizontal, 30° vertical
PIN CONNECTIONS (INPUT)	1+/- or 2+/-	1+/- or 2+/-
PIN CONNECTIONS (LINK)	1+/- and 2+/-	1+/- and 2+/-
DIMENSIONS	(W) 650mm, (H) 369mm, (D) 452mm (W) 25.59ins, (H) 14.51ins, (D) 17.80ins	(W) 650mm, (H) 350mm, (D) 442mm (W) 25.59ins, (H) 13.76ins, (D) 17.40ins
WEIGHT	31kg (68.34 lbs)	26kg (57.32 lbs)

\*Martin Audio continues to specify a crest factor of 2 with 6dB between peak and continuous which best mirrors real-world performance. Simply add a further 6dB for comparison with manufacturers quoting a crest factor of 4 ie. 12dB between continuous and peak.

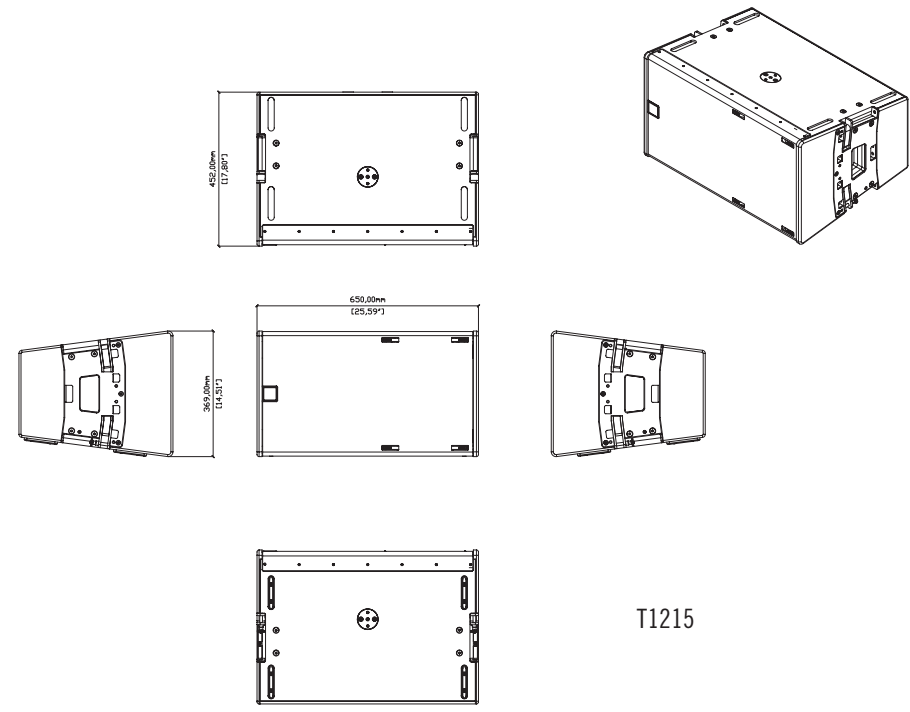

T1215

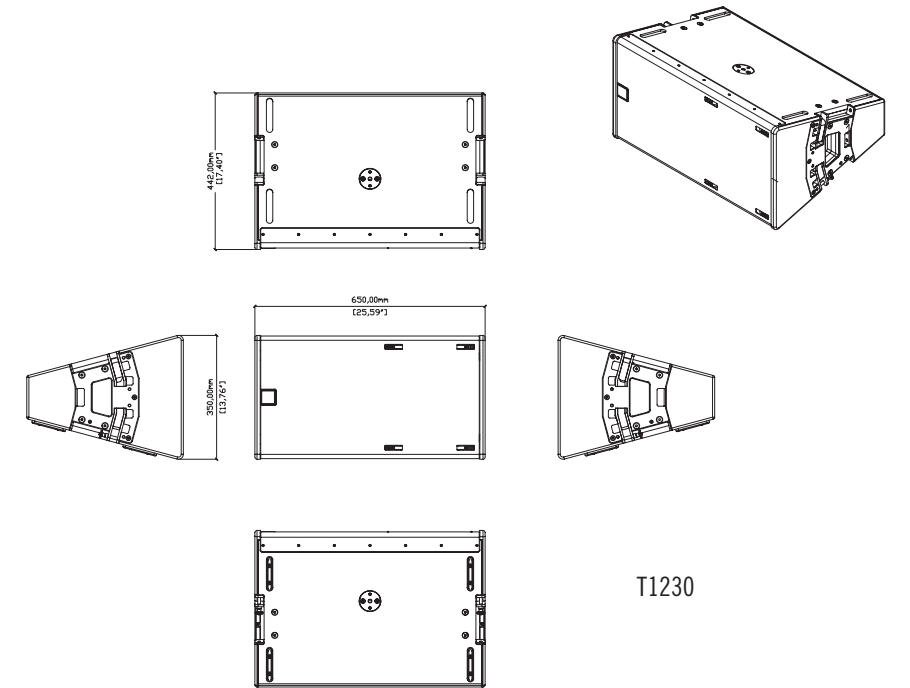

T1230

# TORUS



## Martin Audio Limited

Century Point

Halifax Road

Cressex Business Park

High Wycombe

Buckinghamshire

HP12 3SL

England

## FOR SALES ENQUIRIES:

### UK

Telephone: +44 (0)1494 535312

E-mail: [info@martin-audio.com](mailto:info@martin-audio.com)

### NORTH AMERICA

Telephone: 323 381 5310

[www.martin-audio.com](http://www.martin-audio.com)

All information is Copyright © 2021 Martin Audio Ltd.

Martin Audio, the Martin Audio logo and Hybrid are registered trademarks of Martin Audio Ltd. in the United Kingdom, United States and other countries; all other Martin Audio trademarks are the property of Martin Audio Ltd.



**Unite Your Audience**  
The Martin Audio Experience

Version 1.0